

# ***Yamato***<sup>®</sup>

## **Parts List**

DOUBLE CHAIN STITCH MACHINE  
WITH NEEDLE FEEDING

### **MG2000** SERIES

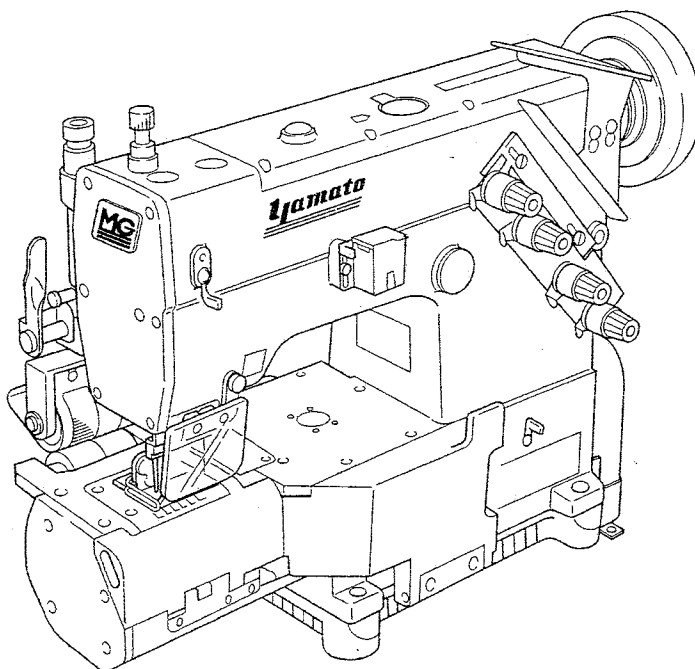

#### **MODELS & DEVICES**

**MG2002    MG2002P    MG2004    MG2004P**

**FL10**

From the library of: Diamond Needle Corp

# パーツリストの見方

このパーツリストはMG2002-349-01Aを基本モデルにしてイラストを作成しています。

項目1～12には基本モデルを記載しています。

項目13～サブモデル、付帯装置等を記載しています。

パーツリストに記載されているカラーの寸法は内径×外径×幅を表わしています。

**記号の説明 (Parts No. の隣に記載されています。)**

[ ] 前回のパーツリストに対して、今回変更された部品を表わしています。

[ ] 内は旧Parts No. 及びネジ類の形状

◆ 前回のパーツリストに対して、今回追加された部品及びモデルを表わしています。

**部品注文の際のご注意**

☆ このパーツリストに記載されている部品をご注文の際は、Parts No.(例えば、4200013)をお願いします。

☆ 0068011の場合は、0068011又は68011でご注文下さい。

☆ エアチューブ御注文の際は品番と長さをお知らせ下さい。

なお、このパーツリストの記載事項は、改良により変更される場合がありますのでご了承下さい。

---

## How to use this Parts List

The illustrations on this Parts List are drawn on the basis of MG2002-349-X01A.

The items from No.1 to No.12 contain the standard model.

The following items included No.13 contain the submodel and Devices.

The dimension of Collar on this Parts List shows Inside diameter X Outside diameter X Width.

**Explanation of Marks (marked at the Side of Part No.)**

[ ] means this part is changed from the previous Parts List.

Inside of [ ] shows the previous Part No. and the shape of screw or the like.

◆ means this part and model is added to the previous Parts List.

**How to place an order for the parts**

☆ When placing an order for the parts from this Parts List, please clearly state the Parts No. (e.g.4200013) which you require so that we can deliver the correct Parts to you.

☆ When the Part No. is "0068011", please place an order for the part by showing "0020538" or "68011".

☆ When ordering Air Tube, please inform us of the Part No. and the length.

This Parts List is subject to change without notice.

# Contents

# 目次

MISCELLANEOUS COVERS (1)	カバー関係(1)	1
MISCELLANEOUS COVERS (2)	カバー関係(2)	2
MISCELLANEOUS THREAD EYELETS	糸道関係	3
MISCELLANEOUS BUSHINGS	ブッシュ関係	4
UPPER SHAFT MECHANISM	上軸機構	5
MAIN SHAFT DRIVING MECHANISM	下軸機構	6
LOOPER DRIVING MECHANISM	ルーパ機構	7
MISCELLANEOUS RETAINER	リテイナ機構	8
NEEDLE BAR MECHANISM	針棒機構	9
PRESSER FOOT MECHANISM	押工機構	10
NEELDE GUARD & FEED DRIVING MECHANISM	送り機構	11
LUBRICATING MECHANISM	給油機構	12
PULLER MECHANISM EXCLUSIVE PARTS (1)	プラー機構専用部品(1)	13
PULLER MECHANISM EXCLUSIVE PARTS (2)	プラー機構専用部品(2)	14
PULLER MECHANISM EXCLUSIVE PARTS (3)	プラー機構専用部品(3)	15
PULLER MECHANISM EXCLUSIVE PARTS (4)	プラー機構専用部品(4)	16
MG2002 EXCLUSIVE PARTS	MG2002 サブモデル専用部品	17
MG2004 EXCLUSIVE PARTS	MG2004 サブモデル専用部品	18
"FL10" DEVICE	"FL10"装置	19
ACCESSORIES (1) (THREAD STAND)	アクセサリ関係(1)(糸立台)	20
ACCESSORIES (2) (BELT COVER)	アクセサリ関係(2)(ベルトカバー)	21
EXTRA PARTS(1)	エキストラパーツ(1)	22
EXTRA PARTS(2)	エキストラパーツ(2)	23
WARNING LABEL	警告ラベル	24
CLASS LIST OF MAIN SPARE PARTS	主要部品リスト	25
INDEX	索引	26

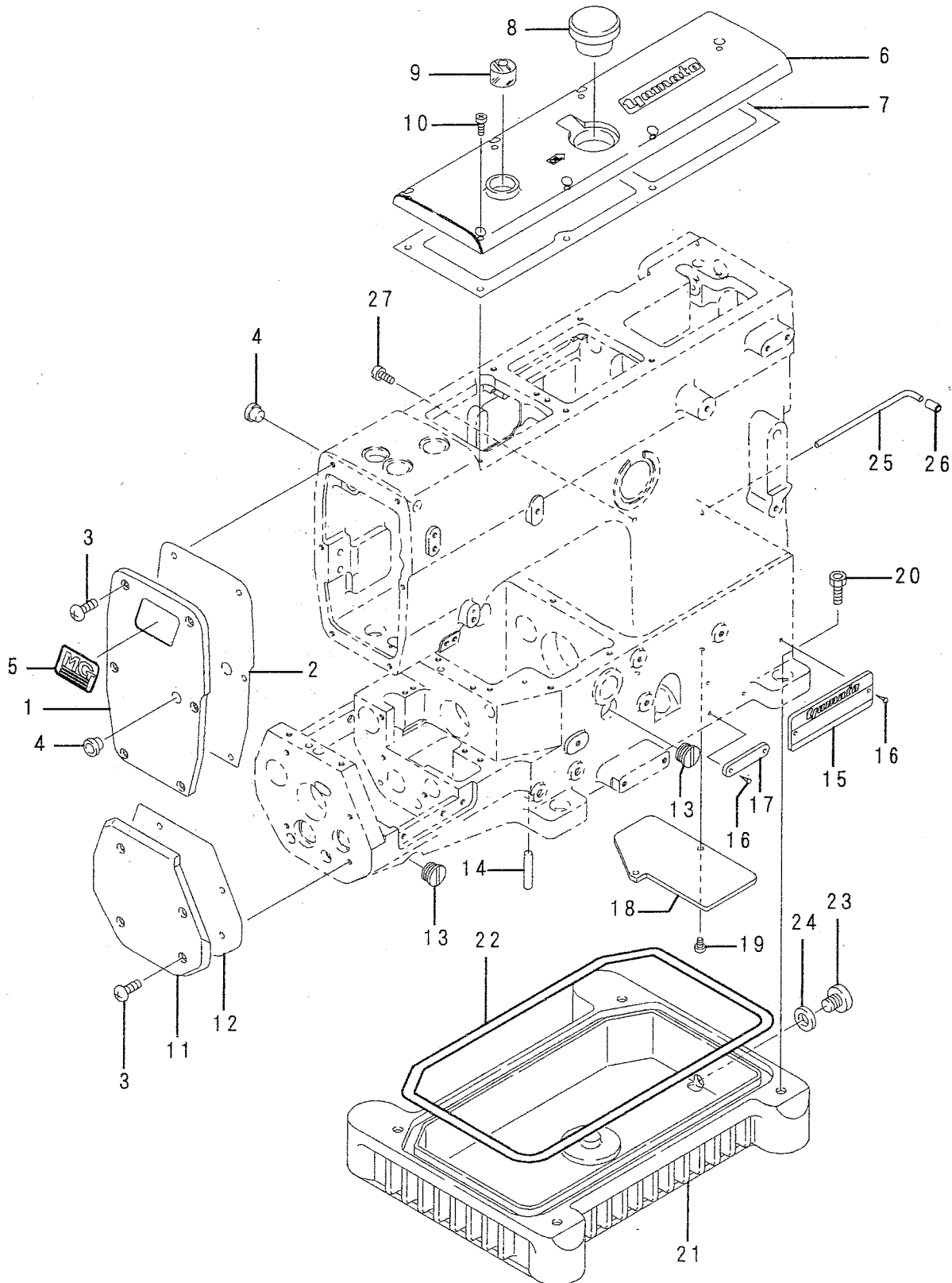

Ref.No.	Parts No.	Description	品名	Amt. Req
1	4200013	Head Cover	ヘッドカバー	1
2	4200014	Head Cover Gasket	ヘッドカバーパッキン	1
3	110048	Screw (M4-0.7X10)	止ネジ	10
4	0093864	Seal Plug	詰栓	2
5	390188	"MG" Emblem	エンブレムMG	1
6	4200050	Top Cover	上カバー	1
7	4200049	Top Cover Gasket	上カバーパッキン	1
8	0020759	Seal Plug	詰栓	1
9	0068011	Oil Sight Window	オイル確認窓	1
10	110045	Screw (M4-0.7X12)	止ネジ	7
11	4200019	Cylinder Cover (Left)	シリンダカバー(左)	1
12	4200030	Cylinder Cover Gasket	シリンダカバーパッキン	1
13	190015	Screw (M14-2X6)	止ネジ	2
14	340000	Machine Frame Supporting Bar	ベッド支工棒	4
15	4109403	Model Plate	形式板	1
16	000726	Rivet	止メ鋸	4
17	2049401	Serial Number Plate	機番プレート	1
18	4200034	Dust Proof Plate	防塵板	1
19	110012	Screw (M4-0.7X5)	止ネジ	2
20	120016	Screw (M8-1.25X20)	止ネジ	4
21	3100004	Oil Reservoir	油受ケ	1
22	3100005	Oil Reservoir Gasket	油受ケパッキン	1
23	005075	Screw (3/8-24X8)	油抜きネジ	1
24	0020137	Drain Hole Seal	油抜きネジパッキン	1
25	0022836	Synchronizer Positioning Pin	ポジションナピン	1
26	0022837	Synchronizer Cushion	ポジションナピンクッション	1
27	110048	Screw (M4-0.7X10)	止ネジ	1

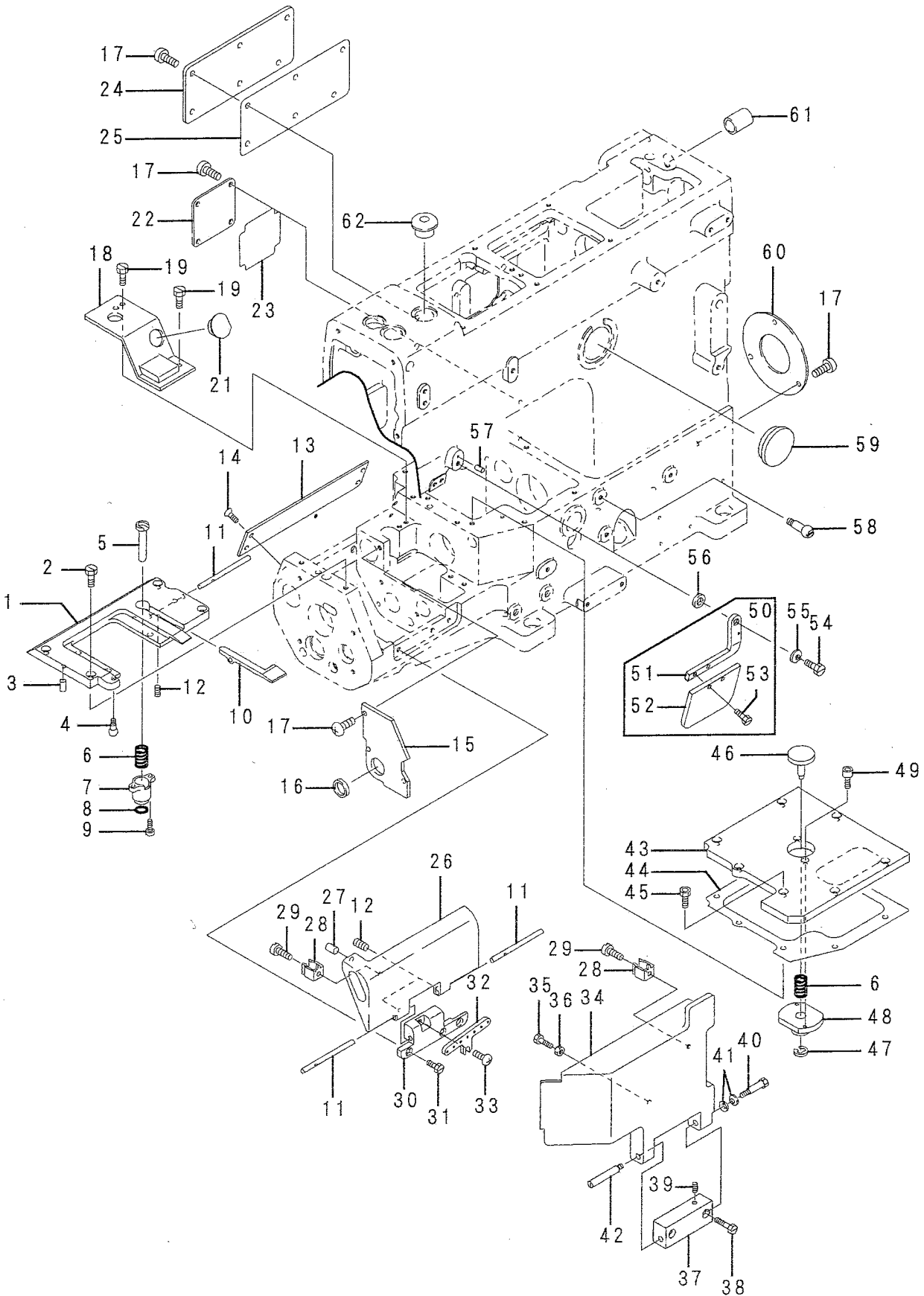

Ref.No.	Parts No.	Description	品名	Amt. Req
1	4200021	Stitch Plate Holder	針板取付台	1
2	110035	Screw (M4-0.7X10)	止ネジ	4
3	000779	Pin	ピン	2
4	190078	Screw (M4-0.7X5)	バネ掛ケネジ	1
5	4200027	Looper Pop-up (Throw-out) Button	ルーパ可倒案内ボタン	1
6	0068374	Spring	バネ	2
7	4200026	Looper Pop-up (Throw-out) Guide	ルーパ可倒案内	1
8	3100205	O Ring (P12)	Oリング	1
9	110032	Screw (M3-0.5X6.5)	止ネジ	2
10	4200028	Looper Throw-out Lever	ルーパ可倒レバー	1
11	340051	Pin (Ø4X25)	平行ピン	3
12	160000	Screw (M3-0.5X3)	止ネジ	3
13	4200020	Cylinder Cover (Rear)	シリンダカバー(後)	1
14	130002	Screw (M3-0.5X6)	止ネジ	4
15	4200044	Looper Eccentric Cover (Left)	ルーパエキセンカバー(左)	1
16	4200141	Oil Seal	オイルシール	1
17	110013	Screw (M4-0.7X8)	止ネジ	16
18	4200045	Looper Eccentric Cover (Upper)	ルーパエキセンカバー(上)	1
19	006202	Screw (M4-0.7X6)	止ネジ	3
20				
21	4200046	Seal Plug	詰栓	1
22	4200041	Rear Cover (Lower)	後カバー(下)	1
23	4200042	Rear Cover (Lower) Gasket	後カバー(下)パッキン	1
24	3100016	Rear Cover	後カバー	1
25	3500432	Rear Cover Gasket	後カバーパッキン	1
26	4200018	Cylinder Cover	シリンダカバー	1
27	000629	Seal Plug	詰栓	1
28	0094201	Cover Latch Spring	カバーラッチバネ	2
29	110012	Screw (M4-0.7X5)	止ネジ	2
30	4200017	Cylinder Cover Hinge	シリンダカバーヒンジ	1
31	110041	Screw (M4-0.7X8)	止ネジ	3
32	4200022	Looper Thread Eyelet (Left)	ルーパ糸通(左)	1
33	007627	Screw (M4-0.7X6)	止ネジ	1
34	4200016	Front Cover	前開キカバー	1
35	120049	Screw (M4-0.7X16)	止ネジ	1
36	100001	Nut	ナット	1
37	4200008	Front Cover Hinge	前開キカバーヒンジ	1
38	110016	Screw (M4-0.7X15)	止ネジ	2
39	160001	Screw (M4-0.7X4)	止ネジ	1
40	170001	Screw (M4-0.7X8)	止ネジ	1

Ref. No. 41 to 62 See the following page.

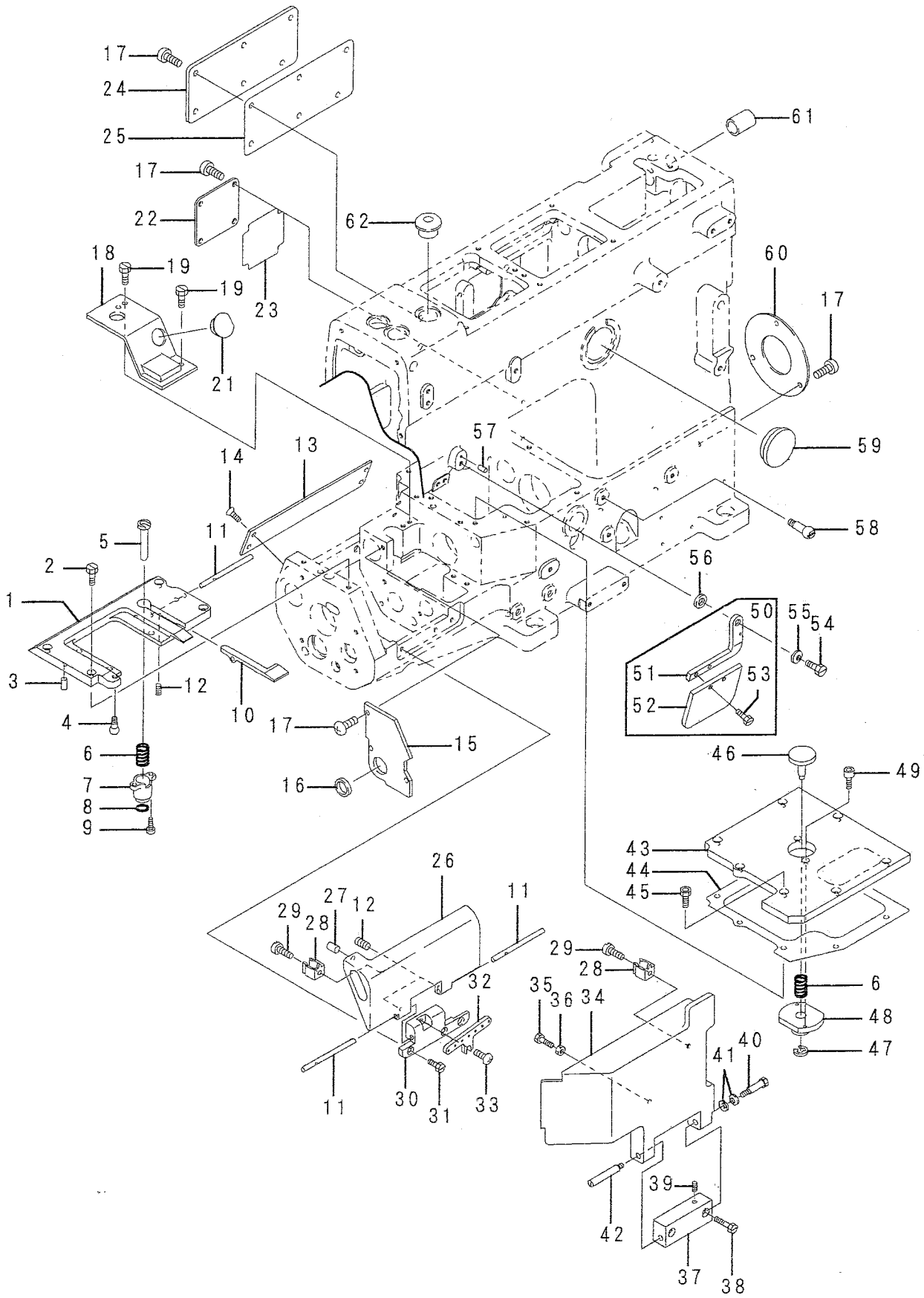



Ref.No.	Parts No.	Description	品名	Amt. Req
41	300100	Conical Spring Washer	皿バネワッシャ	2
42	180005	Screw (M4-0.7X6)	止ネジ	1
43	4200015	Bed Top Cover	ベット上カバー	1
44	4200031	Bed Top Cover Gasket	ベット上カバーパッキン	1
45	120018	Screw (M4-0.7X10)	止ネジ	7
46	4200176	Feed Dog Regulating Button	送り調節ボタン	1
47	0033024	Retaining Ring	ストップリング	1
48	4200177	Button Guide	ボタン案内	1
49	120047	Screw (M3-0.5X8)	止ネジ	2
50	4200051	Eye Guard, C. Set	アイガード(組)	1
51	4200039	Eye Guard Holder	アイガード取付板	1
52	4200040	Eye Guard	アイガード	1
53	110038	Screw (M2.5-0.45X4.5)	止ネジ	2
54	170032	Screw (M4-0.7X5)	止ネジ	1
55	000010	Conical Spring Washer	皿バネワッシャ	2
56	4200038	Eye Guard Stopper	アイガードストッパ	1
57	340022	Pin	ピン	1
58	190005	Screw (M4-0.4X5)	バネ掛ケネジ	1
59	0020759	Seal Plug	詰栓	1
60	4200037	Bearing Cover	ベアリングカバー	1
61	0020052	Seal Plug	詰栓	1
62	3500012	Seal Plug	詰栓	2

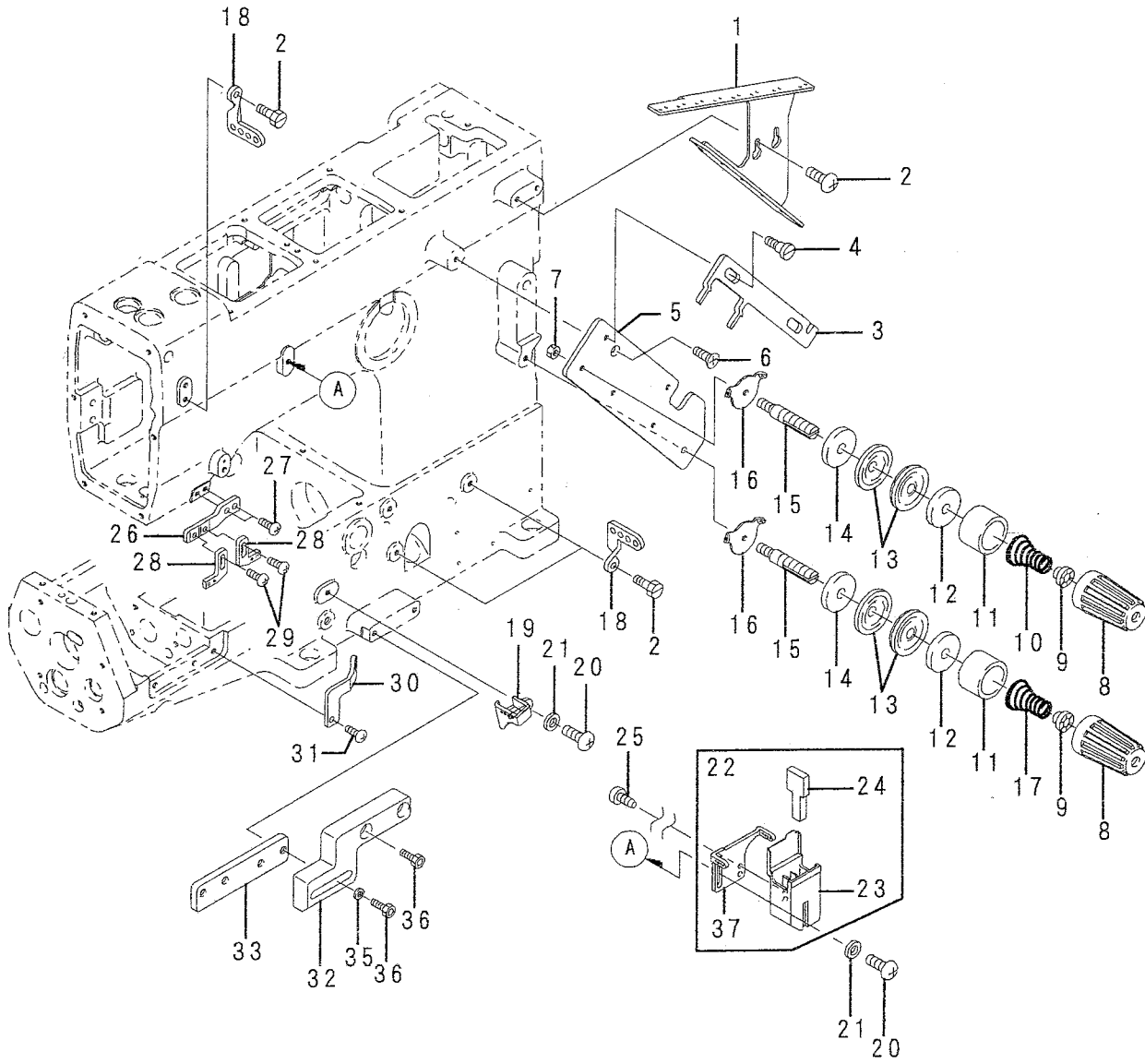

From the library of: Diamond Needle Corp

Ref.No.	Parts No.	Description	品名	Amt. Req
1	4200043	Thread Guide Plate	糸案内板	1
2	110013	Screw (M4-0.7X8)	止ネジ	5
3	4200035	Tension Release Plate	糸緩メ板	1
4	170018	Screw (M4-0.7X2.1)	止ネジ	2
5	4200036	Tension Post Support	糸調子台	1
6	130006	Screw (M4-0.7X10)	止ネジ	1
7	000015	Nut	ナット	3
8	0024084	Thread Tension Spring Cap	糸調子バネキャップ(上)	4
9	0024083	Tension Spring Bushing	回り止め	4
10	0035226	Tension Spring (Needle)	糸調子バネ(針)	2
11	0020118	Thread Tension Spring Retainer	糸調子バネキャップ(下)	4
12	000177	Felt	フェルト	4
13	0031111	Tension Disc	糸調子皿	8
14	000613	Washer	ワッシャ	4
15	190016	Tension Post	糸調子棒	4
16	0020101	Tension Disc Eyelet	糸調子皿糸道	4
17	0032952	Tension Spring (Looper)	糸調子バネ(ルーパ)	2
18	0066650	Eyelet	ルーパ糸道	3
19	4200024	Looper Thread Eyelet (Right)	ルーパ糸道(右)	1
20	110009	Screw (M4-0.7X8)	止ネジ	2
21	000538	Washer	ワッシャ	2
22	3100383	SP Device, C. Set	SP装置(組)	1
23	3100384	SP Container, C. Set	SPタンク(組)	1
24	3100386	Felt	フェルト	1
25	350009	Tapping Screw (3X6mm)	タッピングネジ	1
26	4200047	Needle Thread Eyelet Bracket	針糸道取付板	1
27	110049	Screw (M4-0.7X10)	止ネジ	2
28	4200033	Needle Thread Eyelet	針糸道	2
29	110001	Screw (M4-0.7X5.4)	止ネジ	2
30	4200023	Looper Thread Eyelet (Center)	ルーパ糸道(中)	1
31	110041	Screw (M4-0.7X8)	止ネジ	1
32	4200300	Folder Clamp (1)	定規台(1)	1
33	4200301	Folder Clamp (2)	定規台(2)	1
34				
35	300011	Washer	ワッシャ	2
36	009976	Screw (M6-1X15)	止ネジ	4
37	3100387	Needle Thread Eyelet	針糸道	1

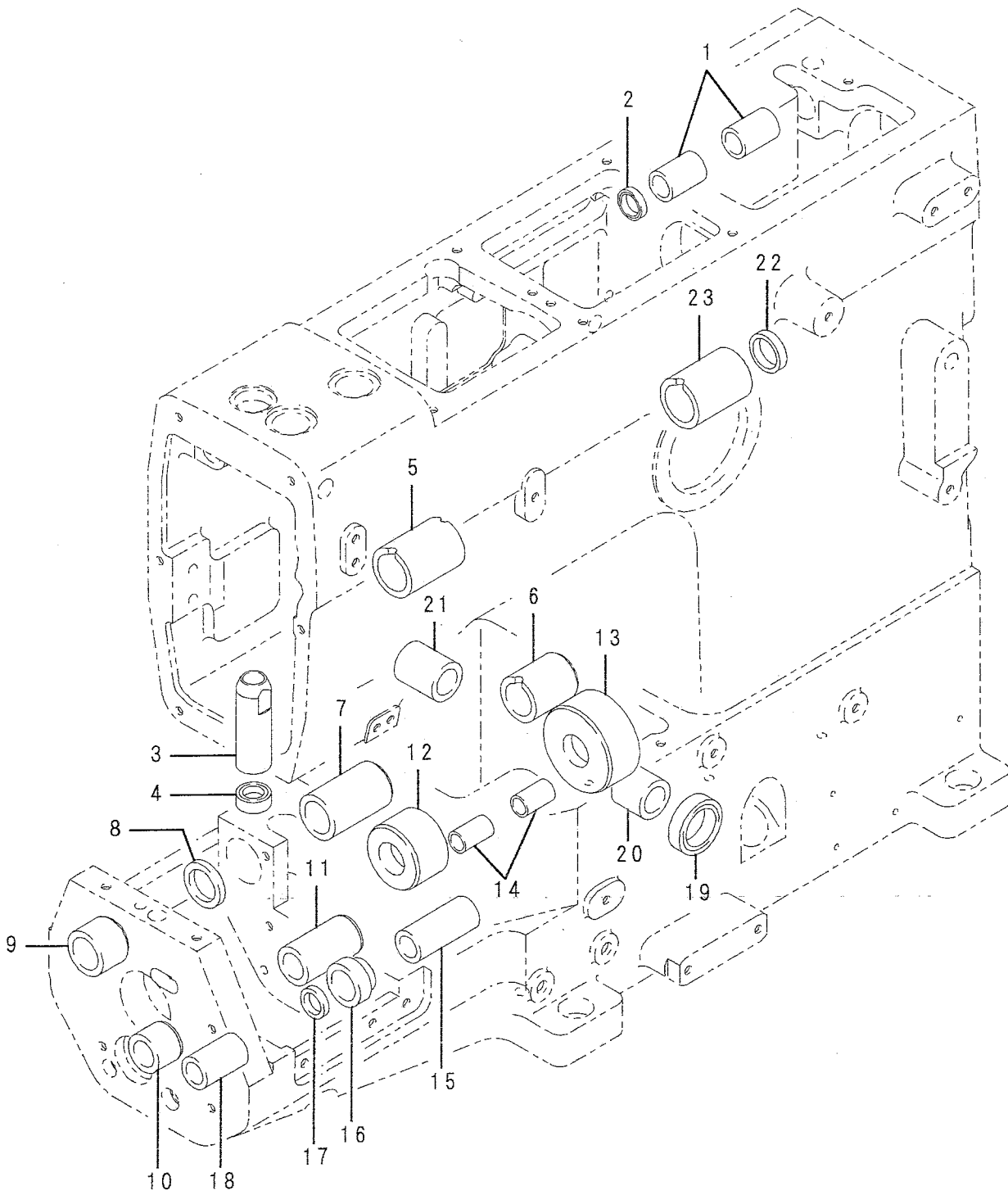

Ref.No.	Parts No.	Description	品名	Amt. Req
1	3500046	Foot Lifter Lever Bushing	押工場ゲ軸ブッシュ	2
2	3500041	Oil Seal	オイルシール	1
3	4200100	Presser Bar Bushing	押工棒ブッシュ	1
4	0030291	Oil Seal	オイルシール	1
5	4200084	Needle Driving Bushing (Right)	針振り軸ブッシュ(右)	1
6	4200164	Feed Drive Shaft Bushing (Right)	送り前後軸ブッシュ(右)	1
7	4200163	Feed Drive Shaft Bushing (Middle)	送り前後軸ブッシュ(中)	1
8	4200136	Oil Seal	オイルシール	1
9	4200162	Feed Drive Shaft Bushing (Left)	送り前後軸ブッシュ(左)	1
10	4200179	Feed Lift Shaft Bushing (Left)	送り上下軸ブッシュ(左)	1
11	4200180	Feed Lift Shaft Bushing (Right)	送り上下軸ブッシュ(右)	1
12	4200062	Lower Shaft Bushing (Left)	下軸ブッシュ(左)	1
13	4200063	Lower Shaft Bushing (Right)	下軸ブッシュ(右)	1
14	4200129	Retainer Rocker Shaft Bushing	リテイナ左軸ブッシュ	2
15	4200140	Looper Shaft Bushing (Right)	ルーパ台軸ブッシュ(右)	1
16	4200139	Looper Shaft Bushing (Middle)	ルーパ台軸ブッシュ(中)	1
17	4200137	Oil Seal	オイルシール	1
18	4200138	Looper Shaft Bushing (Left)	ルーパ台軸ブッシュ(左)	1
19	0032684	Oil Seal	オイルシール	1
20	4200128	Retainer Driving Shaft Bushing (Front)	リテイナ軸ブッシュ(前)	1
21	4200127	Retainer Driving Shaft Bushing (Rear)	リテイナ軸ブッシュ(後)	1
22	2150069	Seal Plug	詰栓	1
23	4200097	Needle Driving Bushing (Left)	針振り軸ブッシュ(左)	1

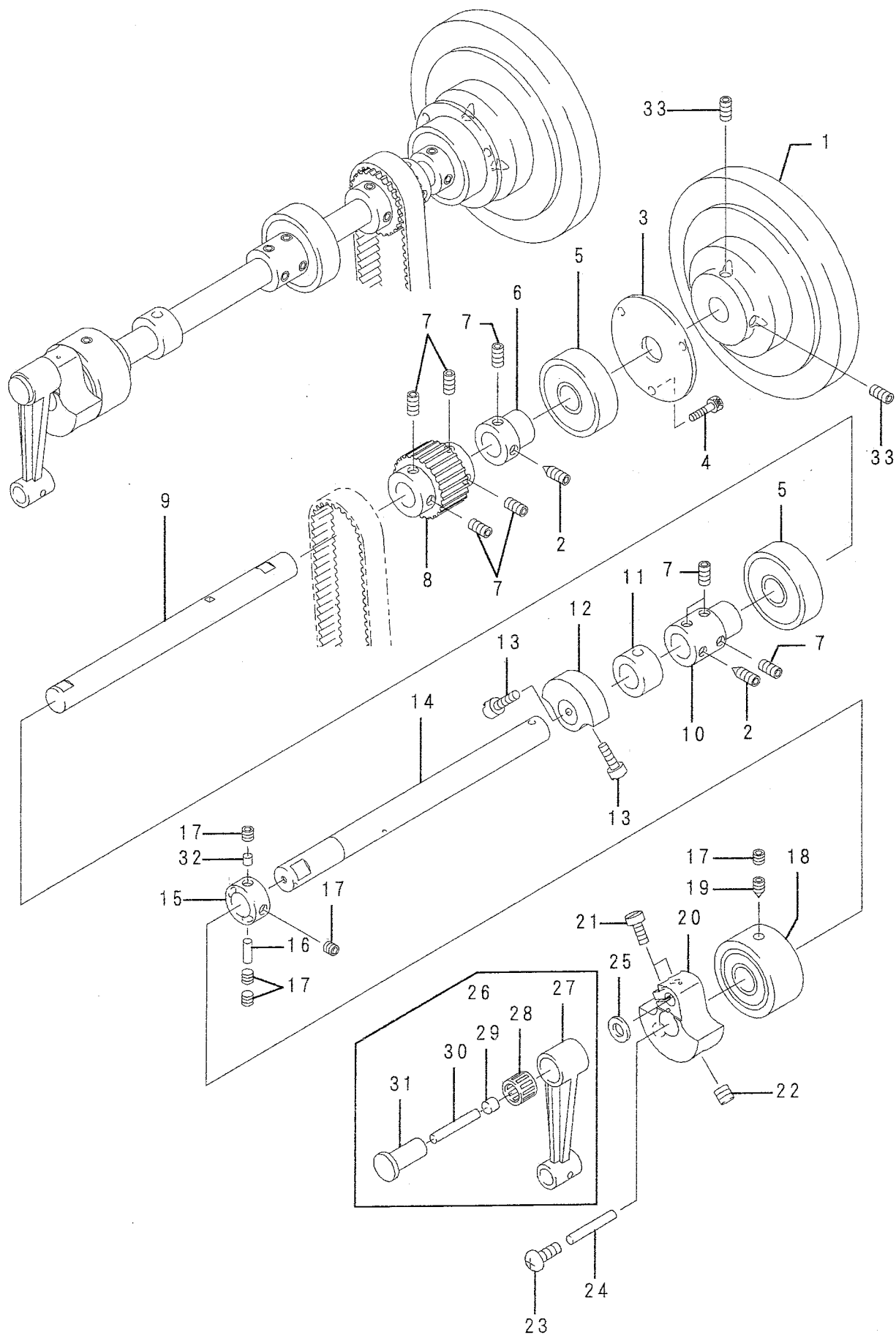

Ref.No.	Parts No.	Description	品名	Amt. Req
1	4200065	Handwheel	ハンドホイール	1
2	160005	Screw (M6-1X8)	止ネジ	2
3	4200055	Bearing Cover (Upper)	ベアリングカバー(上)	1
4	110013	Screw (M4-0.7X8)	止ネジ	3
5	3500054	Ball Bearing	ベアリング	2
6	3100129	Hand Wheel Adapter	アダプタ	1
7	160007	Screw (M6-1X6)	止ネジ	7
8	4200213	Upper Shaft Sprocket	ベルトプーリ(上)	1
9	4200108	Upper Shaft (Right)	上軸(右)	1
10	3100283	Upper Shaft Joint	上軸継手	1
11	3500403	Oil Sleeve	オイルスリーブ	1
12	3100127	Counterweight	バランスウエイト	1
13	110009	Screw (M4-0.7X8)	止ネジ	2
14	4200070	Upper Shaft (Left)	上軸(左)	1
15	4200071	Collar (15X32X12mm)	カラー	1
16	310121	Oil Wick	油芯	1
17	160004	Screw (M6-1X4.8)	止ネジ	5
18	3500062	Upper Shaft Sleeve, C. Set	上軸スリーブ(組)	1
19	160031	Screw	六角穴ネジ	1
20	4200067	Counterweight	バランスウエイト	1
21	110011	Screw (M5-0.8X10)	止ネジ	2
22	160029	Screw (M8-1.25X8)	止ネジ	2
23	110067	Screw (M5-0.8X5)	止ネジ	1
24	310120	Oil Wick	油芯	1
25	0093214	Connecting Rod Ring	針棒ロッドリング	1
26	4200099	Connection Rod, C. Set	針棒ロッド(組)	1
27	3200112	Connection Rod	針棒ロッド	1
28	0093212	Roller Bearing	ニードルベアリング	1
29	330000	Seal Plug	詰栓	1
30	000309	Oil Wick	油芯	1
31	4200098	Pin	針棒ロッドピン	1
32	330013	Seal Plug	詰栓	1
33	160024	Screw (M6-1X8)	止ネジ	2

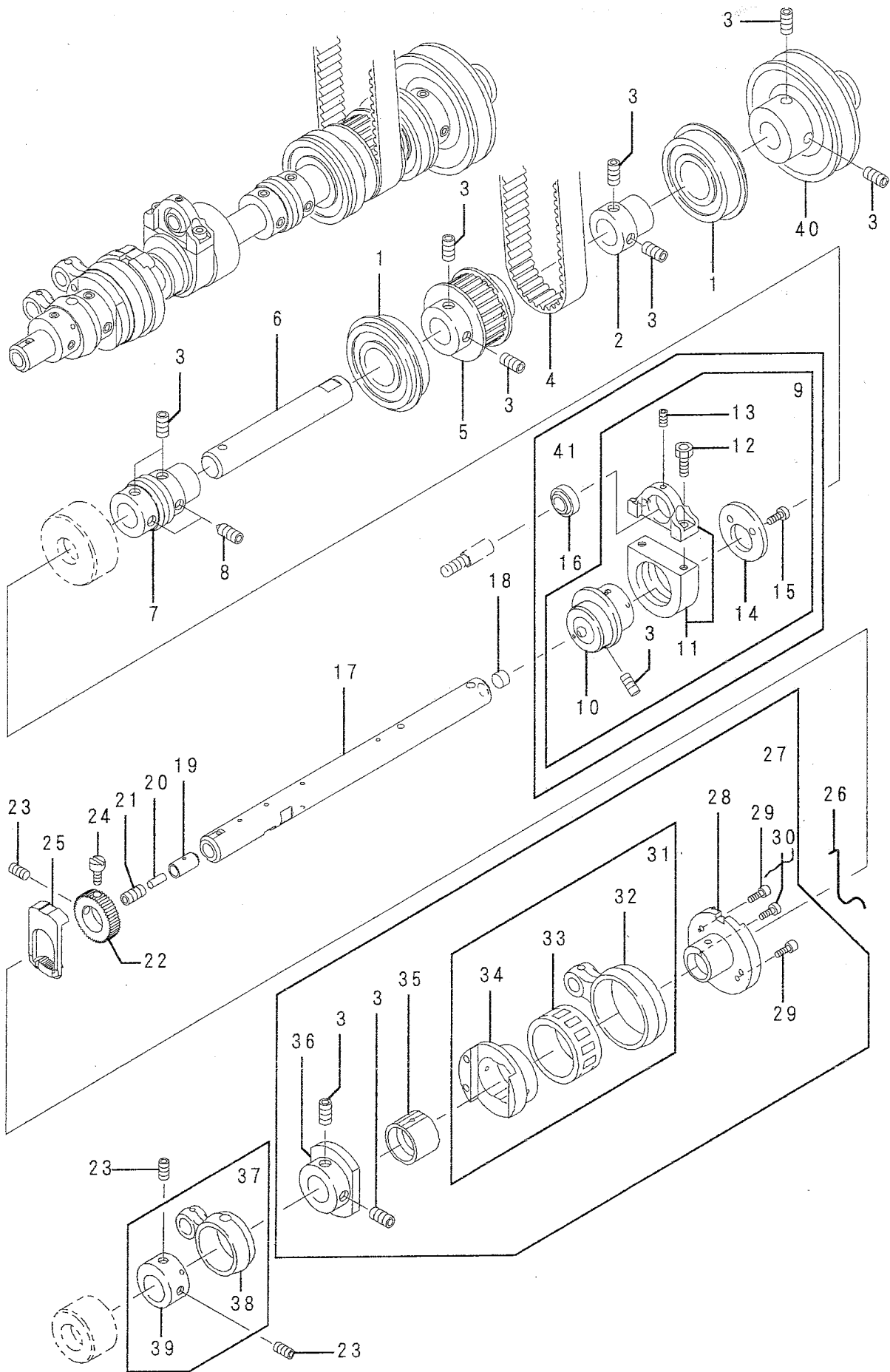

From the library of: Diamond Needle Corp



Ref.No.	Parts No.	Description	品名	Amt. Req
1	0093090	Ball Bearing	ベアリング	2
2	3100129	Hand Wheel Adapter	アダプタ	1
3	160007	Screw (M6-1X6)	止ネジ	12
4	4200029	Timing Belt (615-5GT-23)	タイミングベルト	1
5	4200214	Lower Shaft Sprocket	ベルトプーリ(下)	1
6	4200109	Lower Shaft (Right)	下軸(右)	1
7	3100122	Oil Pump Driving Worm	ウォーム	1
8	160005	Screw (M6-1X8)	止ネジ	2
9	4200126	Retainer Rod, C. Set 1	リテナロッド(組1)	1
10	4200122	Retainer Eccentric	リテナエキセン	1
11	4200123	Retainer Rod, C. Set	リテナロッド(組)	1
12	120018	Screw (M4-0.7X10)	止ネジ	2
13	160000	Screw (M3-0.5X3)	止ネジ	1
14	4200124	Rod Cover	リテナロッド蓋	1
15	130003	Screw (M4-0.7X7.3)	止ネジ	2
16	4200125	Bearing	球面滑り軸受ケ	1
17	4200060	Lower Shaft (Left)	下軸(左)	1
18	330006	Seal Plug	詰栓	1
19	4200064	Oil Pressure Regulating Valve	調圧管	1
20	000392	Oil Wick	油芯	1
21	160004	Screw (M6-1X4.8)	止ネジ	1
22	2110566	Feed Dog Regulating Gear	送り調節ギヤ	1
23	160003	Screw (M5-0.8X5)	止ネジ	3
24	180003	Screw (M5-0.8X8)	止ネジ	1
25	4200169	Feed Dog Regulating Plate	送り調節プレート	1
26	4200184	Feed Dog Regulating Plate Spring	送り調節プレートバネ	1
27	4200175	Feed Dog Regulator, C. Set	送り調節器(組)	1
28	4200168	Feed Dog Regulating Eccentric	送り調節エキセン	1
29	180002	Screw (M3-0.5X4)	止ネジ	2
30	110070	Screw (M3-0.5X6.3)	止ネジ	1
31	4200174	Feed Drive Eccentric, C. Set	送り前後エキセン(組)	1
32	4200167	Feed Drive Rod	送り前後ロッド	1
33	4200173	Roller Bearing	ニードルベアリング	1
34	4200172	Feed Drive Eccentric	送り前後エキセン	1
35	4200171	Eccentric Link	エキセンリンク	1
36	4200170	Feed Dog Regulator	送り調節器	1
37	4200185	Feed Lift Rod, C. Set	送り上下ロッド(組)	1
38	4200150	Feed Lift Rod	送り上下ロッド	1
39	4200152	Feed Lift Eccentric	送り上下エキセン	1
40	4200066	Pulley	プーリ	1
41	4200142	Retainer Rod, C. Set 2	リテナロッド(組2)	1

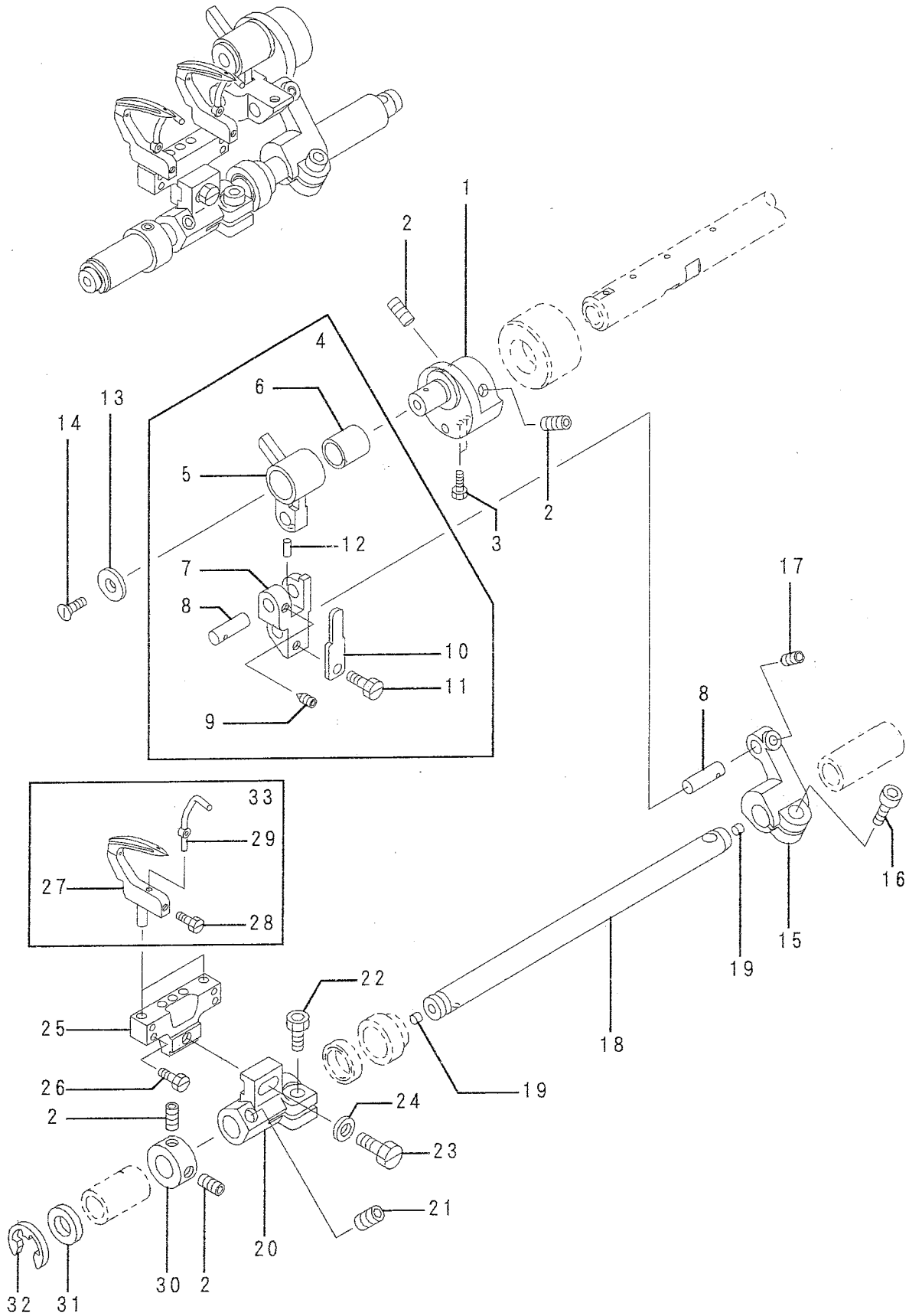

Ref.No.	Parts No.	Description	品名	Amt. Req
1	4200114	Looper Eccentric	ルーパエキセン	1
2	160003	Screw (M5-0.8X5)	止ネジ	4
3	110127	Screw (M3-0.5X8.2)	止ネジ	2
4	4200118	Looper Rod, C. Set	ルーパロッド(組)	1
5	4200110	Looper Rod	ルーパロッド	1
6	4200116	Looper Eccentric Bushing	ルーパエキセンブッシュ	1
7	4200111	Looper Link	ルーパリンク	1
8	4200115	Pin	ピン	2
9	160037	Screw (M4-0.7X8)	止ネジ	1
10	4200113	Looper Rod Hold Spring	ルーパロッド固定バネ	1
11	110009	Screw (M4-0.7X8)	止ネジ	1
12	000290	Oil Wick	油芯	1
13	4200117	Looper Rod Cover	ルーパロッド蓋	1
14	130002	Screw (M3-0.5X6)	止ネジ	1
15	4200112	Looper Holder	ルーパ台腕	1
16	120013	Screw (M6-1X15)	止ネジ	1
17	160002	Screw (M4-0.7X5)	止ネジ	1
18	4200120	Looper Holder Shaft	ルーパ台軸	1
19	000740	Seal Plug	詰栓	2
20	4200119	Looper Holder (Lower)	ルーパ台(下)	1
21	160007	Screw (M6-1X6)	止ネジ	1
22	120006	Screw (M6-1X12)	止ネジ	1
23	004176	Screw (M5-0.8X12)	止ネジ	1
24	300000	Washer	ワッシャ	1
25	4209315	Looper Holder (34.9mm)	ルーパ台	1
26	110126	Screw (M3-0.5X7)	止ネジ	4
27	4209325	Looper	ルーパ	2
28	120056	Screw (M3-0.5X5)	止ネジ	2
29	4209201	Needle Guard (Rear)	針受ケ(後)	2
30	2100161	Collar (10X19X9mm)	カラー	1
31	2150075	Thrust Ring	スラストリング	1
32	0095027	Retaining Ring	ストップリング	1
33	4209326	Looper Needle Guard, C. Set	ルーパ・針受ケ(組)	2

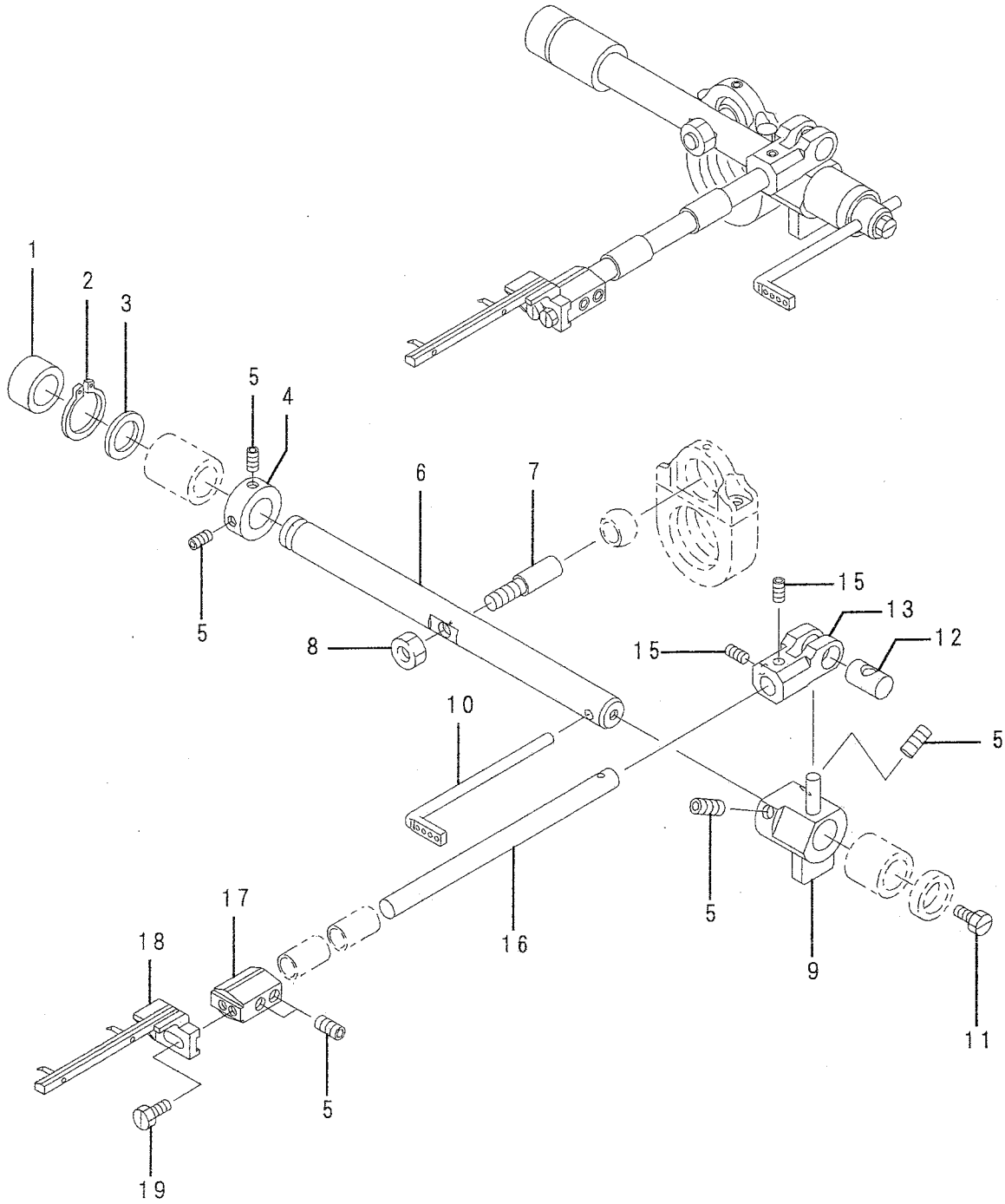

Ref.No.	Parts No.	Description	品名	Amt. Req
1	3100006	Seal Plug	詰栓	1
2	0034117	Retaining Ring	ストップリング	1
3	4200155	Thrust Ring	スラストリング	1
4	2100137	Collar (10X19X9mm)	カラー	1
5	160003	Screw (M5-0.8X5)	止ネジ	6
6	4200133	Retainer Driving Shaft	リテナ駆動軸	1
7	4200130	Pin Screw	ピンネジ	1
8	100041	Nut	ナット	1
9	4200132	Retainer Rocker Arm	リテナ左右振腕	1
10	4200025	Looper Thread Take-up	ルーパ糸操り	1
11	110009	Screw (M4-0.7X8)	止ネジ	1
12	4200134	Retainer Rocker Driving Lever Pin	リテナ左右軸腕ピン	1
13	4200131	Retainer Rocker Driving Lever	リテナ左右軸腕	1
14				
15	160001	Screw (M5-0.7X4)	止ネジ	2
16	4200121	Retainer Rocker Shaft	リテナ左右軸	1
17	4200135	Retainer Holder	リテナ台	1
18	4209301	Retainer (34.9mm)	リテナ	1
19	140010	Screw (M4-0.7X8)	止ネジ	2

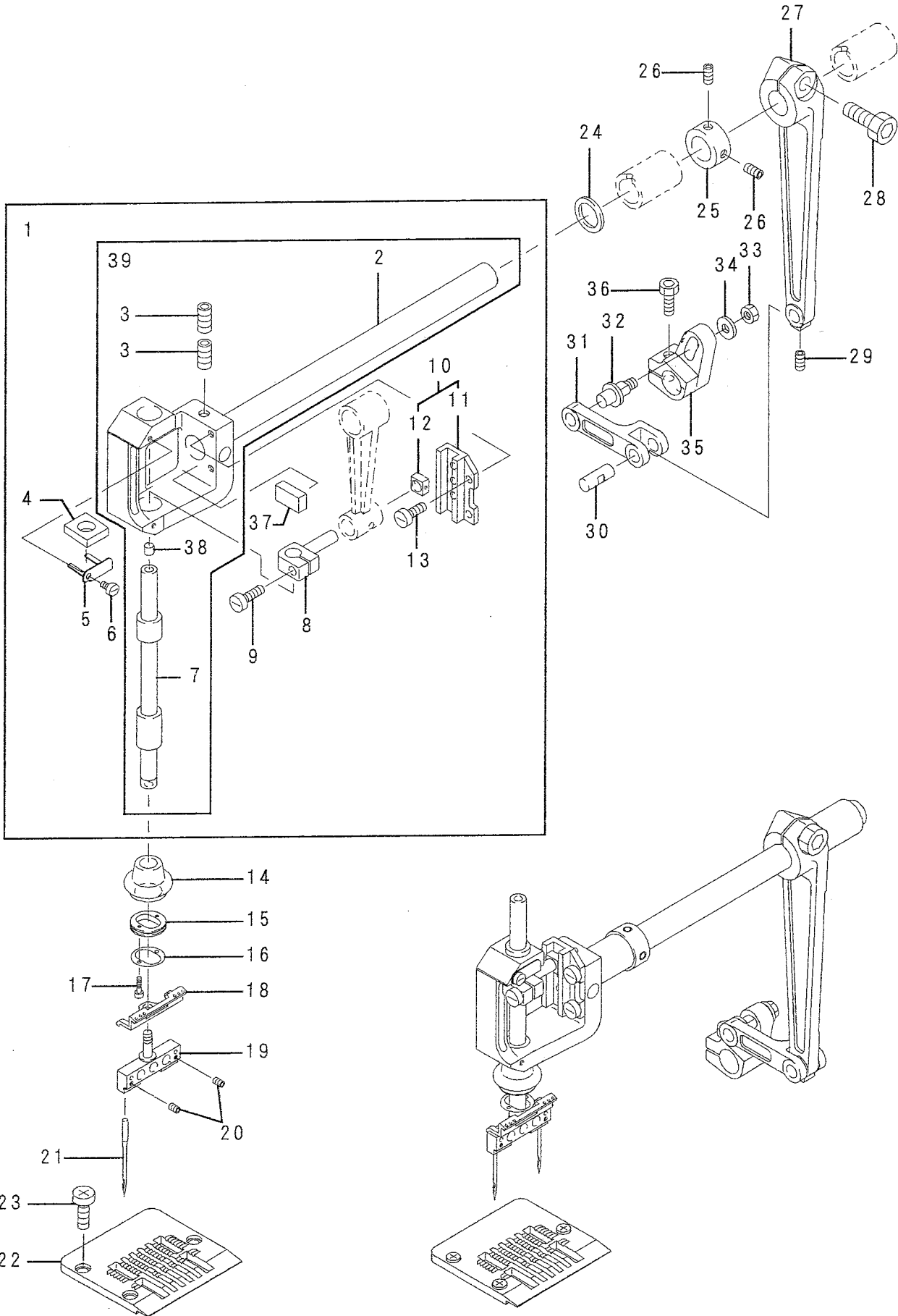

Ref.No.	Parts No.	Description	品名	Amt. Req
1	4200082	Needle Bar Yoke, C. Set 3	針振り台(組3)	1
2	4200080	Needle Bar Yoke, C. Set 1	針振り台(組1)	1
3	160007	Screw (M6-1X6)	止ネジ	2
4	310117	Felt	フェルト	1
5	4200096	Felt Clamp	フェルト押工	1
6	110030	Screw (M3-0.5X2.6)	止ネジ	1
7	4200094	Needle Bar and Bushing, C. Set	針棒・針棒ブッシュ	1
8	4200092	Needle Bar Bracket	針棒抱キ	1
9	110021	Screw (M5-0.8X18)	止ネジ	1
10	4200091	Needle Bar Guide, C. Set	針棒案内(組)	1
11	4200089	Needle Bar Guide	針棒案内	1
12	4200090	Needle Bar Guide Block	針棒案内駒	1
13	110049	Screw (M4-0.7X10)	止ネジ	2
14	4200072	Oil Shield	防油カバー	1
15	4200073	Oil Shield Support	防油カバーサポート	1
16	4200076	Spacer	スペーサ	1
17	120055	Screw (M2-0.4X8)	止ネジ	2
18	4200048	Needle Thread Take-up	針糸操り	1
19	4209100	Needle Clamp (34.9mm)	針止メ	1
20	001900	Screw (1/8-44X2.4)	止ネジ	2
21		Needle (DVX57)	針	2
22	4208000	Stitch Plate (34.9mm)	針板	1
23	110125	Screw (M5-0.8X7)	止ネジ	3
24	4200078	Thrust Ring	スラストリング	1
25	4200083	Collar (17X26X11mm)	カラー	1
26	160003	Screw (M5-0.8X5)	止ネジ	2
27	4200085	Driving Lever	針振り軸腕	1
28	009972	Screw (M8-1.25X20)	止ネジ	1
29	160001	Screw (M4-0.7X4)	止ネジ	1
30	4200095	Link Pin	リンクピン	1
31	4200087	Needle Rocker Link	針振りリンク	1
32	4200088	Pin	針振りレバーピン	1
33	100041	Nut	ナット	1
34	000528	Washer	ワッシャ	1
35	4200086	Needle Rocker Lever	針振りレバー	1
36	120013	Screw (M6-1X15)	止ネジ	1
37	4200200	Sponge	給油スポンジ	1
38	000629	Seal Plug	詰栓	1
39	4200081	Needle Bar Yoke, C. Set 2	針振り台(組2)	1

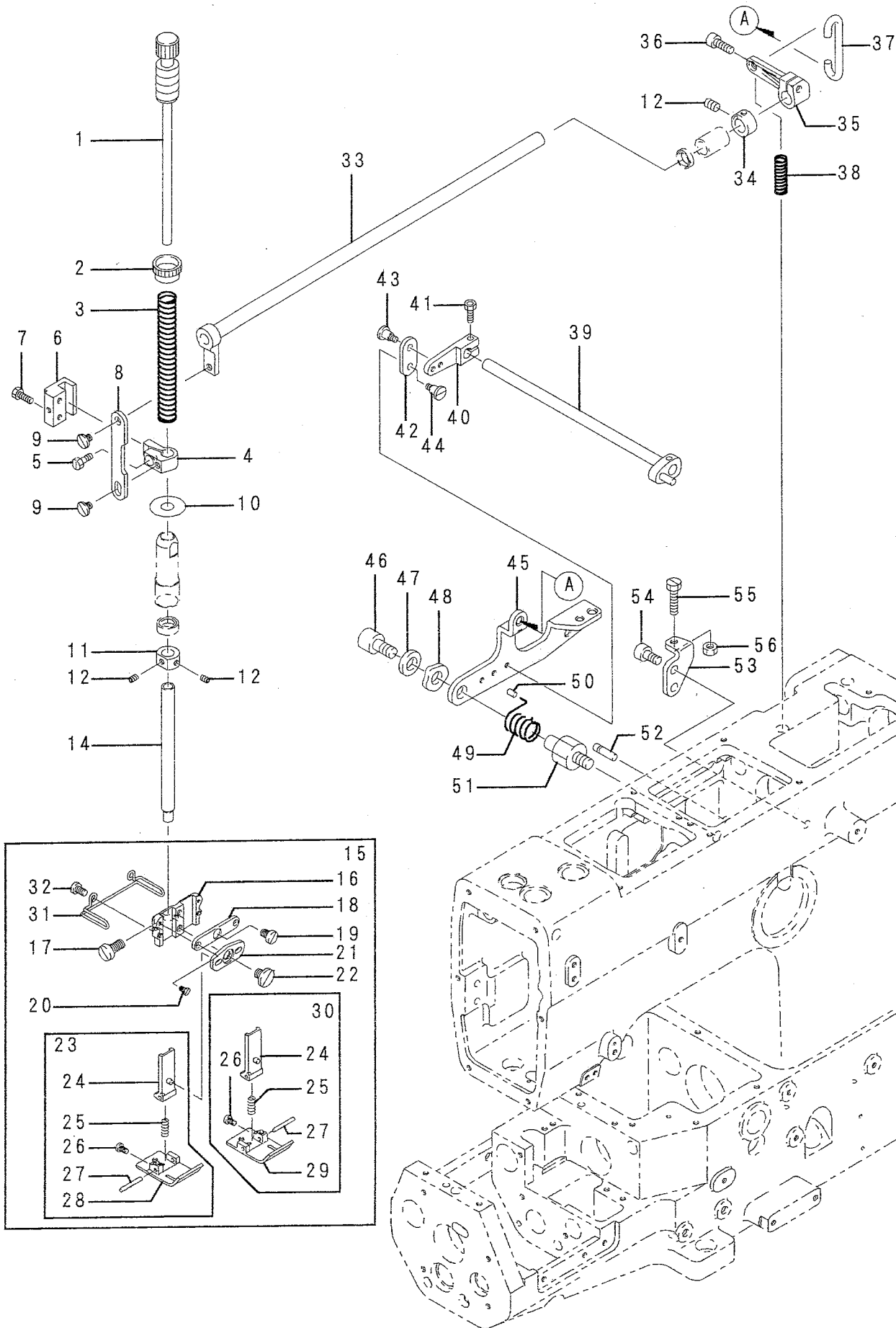



Ref.No.	Parts No.	Description	品名	Amt. Req
1	0077270	Presser Spring Regulator	押工調節ネジ	1
2	000445	Lock Nut	ロックナット	1
3	4200104	Presser Bar Spring (Outer)	押工棒バネ(太)	1
4	4200101	Presser Bar Holder	押工棒抱キ	1
5	110035	Screw (M4-0.7X10)	止ネジ	1
6	0093483	Presser Bar Guide	押工棒案内	1
7	004441	Screw (11/64-40X16)	止ネジ	2
8	4200103	Link	吊りリンク	1
9	170041	Screw (M5-0.8X35)	止ネジ	2
10	0093611	Oil Protector Ring	油切りリング	1
11	2100443	Collar (9X17X8mm)	カラー	1
12	160001	Screw (M4-0.7X4)	止ネジ	4
13				
14	4200102	Presser Bar	押工棒	1
15	4207007	Presser Foot, C. Set (34.9mm)	押工(組)	1
16	4207002	Presser Foot (Upper)	押工(上)	1
17	110011	Screw (M5-0.8X10)	止ネジ	1
18	4207000	Presser Foot Guide	押工ガイド板	1
19	110001	Screw (M4-0.7X5.4)	止ネジ	1
20	130001	Screw (M2.5-0.45X6)	止ネジ	2
21	4207008	Presser Foot (Lower) Guide	押工(下)ガイド板	1
22	170053	Screw (M5-0.8X4.5)	止ネジ	1
23	4207005	Presser Foot (Left), C. Set (34.9mm)	押工下(左)(組)	1
24	4207001	Presser Foot (Lower) Guide	押工(下)ガイド	2
25	4207011	Presser Foot (Lower) Spring	押工下バネ	2
26	110084	Screw (M3-0.5X4.2)	止ネジ	2
27	340053	Pin	ピン	2
28	4207003	Presser Foot (Left) (34.9mm)	押工下(左)	1
29	4207004	Presser Foot (Right) (34.9mm)	押工下(右)	1
30	4207006	Presser Foot (Right), C. Set (34.9mm)	押工下(右)(組)	1
31	4207010	Finger Guard	フィンガード	1
32	110003	Screw (M3.5-0.6X6)	止ネジ	2
33	3500300	Lifter Shaft, C. Set	押工揚ゲ軸(組)	1
34	2100267	Collar (10X17X8mm)	カラー	1
35	3500293	Lifter Shaft Lever	押工揚ゲ軸レバー	1
36	005650	Screw (M5-0.8X14)	止ネジ	1
37	3500294	Lever Link	レバーリンク	1
38	0068181	Spring	バネ	1
39	4200052	Tension Release Shaft	糸緩メ軸	1
40	3100533	Tension Release Lever	糸緩メ腕	1

Ref. No. 41 to 56 See the following page.

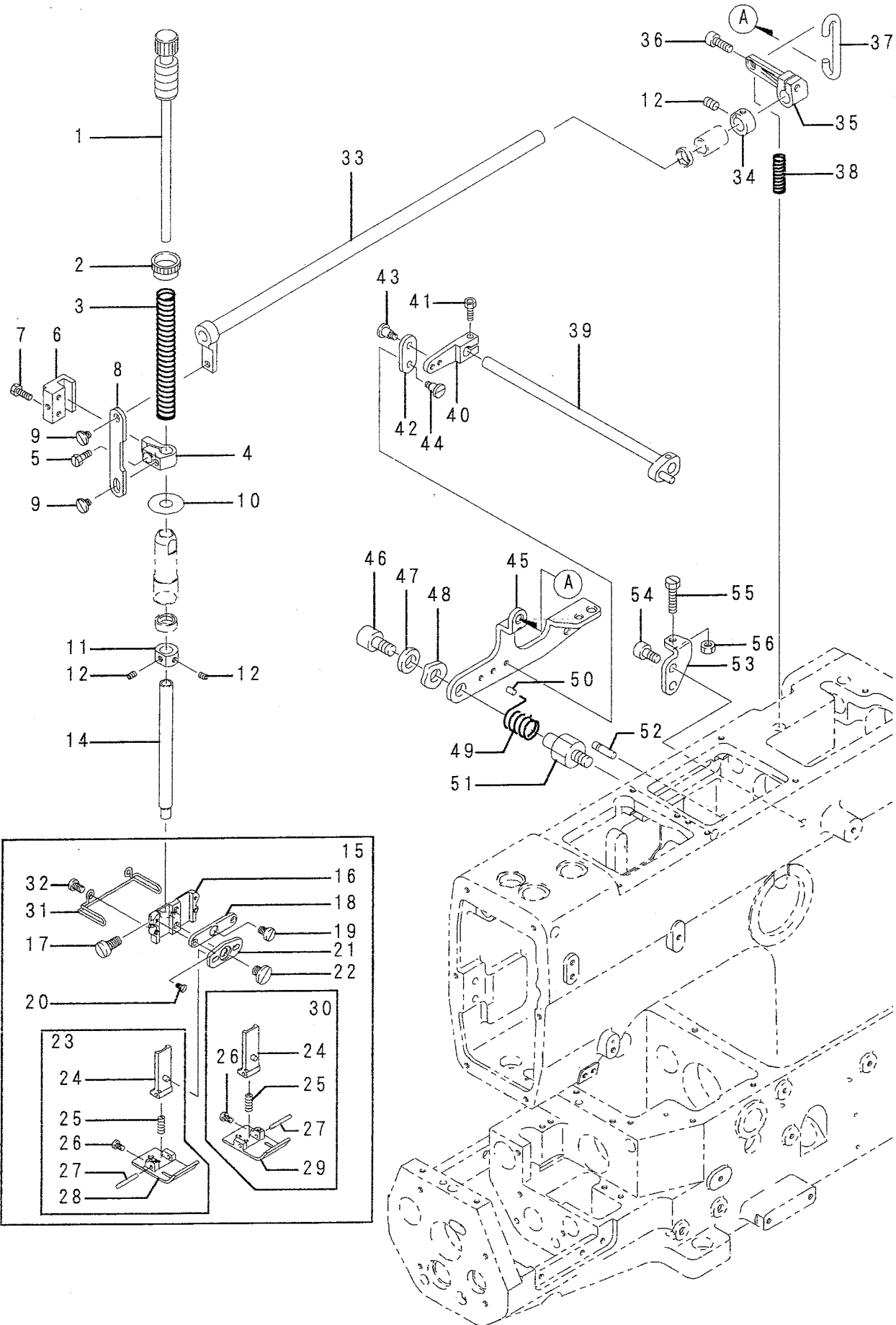

Ref.No.	Parts No.	Description	品名	Amt. Req
41	120001	Screw (M4-0.7X14)	止ネジ	1
42	3500299	Tension Release Lever Connector	糸緩メ腕連結板	1
43	170009	Screw (M4-0.7X4)	止ネジ	1
44	170038	Screw (M4-0.7X5)	止ネジ	1
45	3500291	Lifter Lever	押工揚ゲレバー	1
46	120010	Screw (M6-1X10)	止ネジ	1
47	300005	Washer	ワッシャ	1
48	000487	Wave Washer	波形ワッシャ	1
49	2110361	Spring	押工揚ゲレバーバネ	1
50	3500305	Cap	キャップ	1
51	2100194	Lifter Lever Holder	押工揚ゲレバー台	1
52	340003	Knock Pin	バネ掛ケピン	1
53	3500295	Lifter Lever Stopper	押工揚ゲレバーストッパ	1
54	120006	Screw (M6-1X12)	止ネジ	2
55	110021	Screw (M5-0.8X18)	止ネジ	1
56	000206	Nut	ナット	1

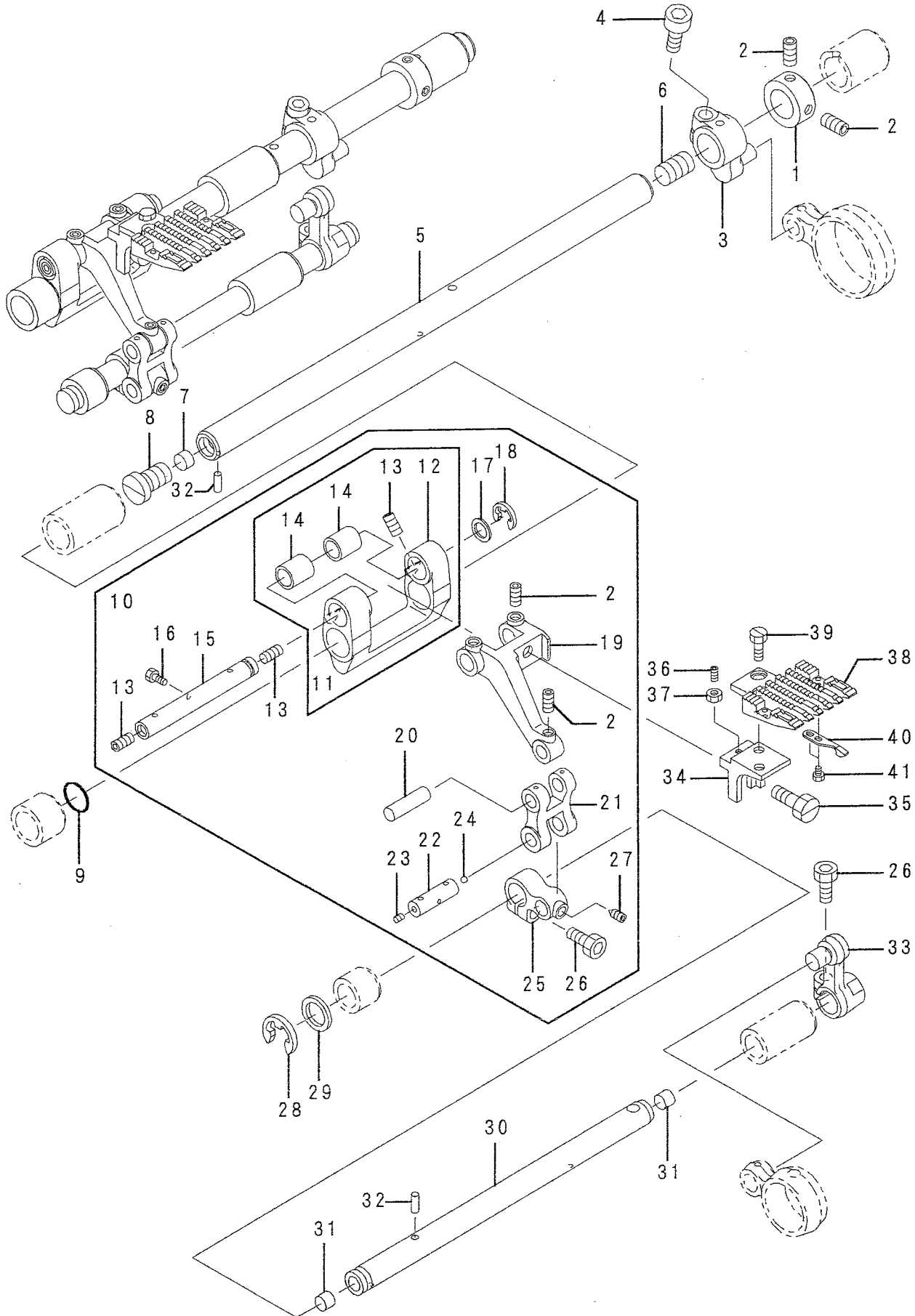

Ref.No.	Parts No.	Description	品名	Amt. Req
1	4200188	Collar (15X24X11mm)	カラー	1
2	160003	Screw (M5-0.8X5)	止ネジ	5
3	4200166	Feed Driving Lever	送り前後軸腕	1
4	120011	Screw (M6-1X18)	止ネジ	1
5	4200165	Feed Drive Shaft	送り前後軸	1
6	160020	Screw (M10-1.5X10)	止ネジ	1
7	310119	Oil Wick	油芯	
8	110116	Screw (M10-1.5X4)	止ネジ	1
9	0090351	O Ring (P15)	Oリング	1
10	4200178	Feed Bar, C. Set	送り台(組)	1
11	4200186	Feed Bar, C. Set 1	送り台(組1)	1
12	4200160	Feed Bar	送り台	1
13	160007	Screw (M6-1X6)	止ネジ	4
14	4200182	Feed Bar Bush	送り台ブッシュ	2
15	4200161	Feed Bar Shaft	送り台軸	1
16	110030	Screw (M3-0.5X2.6)	止ネジ	1
17	4200187	Thrust Ring	スラストリング	1
18	0095027	Retaining Ring	ストップリング	1
19	4200158	Feed Dog Bracket (Lower)	送り取付台(下)	1
20	0032921	Upper Feed Roller Driving Rod Pin	上メスロッドピン	1
21	4200156	Feed Lift Link	送り上下リンク	1
22	4200157	Link Pin	リンクピン	1
23	160000	Screw (M3-0.5X3)	止ネジ	1
24	000637	Seal Plug	詰栓	1
25	4200154	Feed Lift Driving Lever (Left)	送り上下軸腕(左)	1
26	120013	Screw (M6-1X15)	止ネジ	2
27	160021	Screw (M6-1X12)	止ネジ	1
28	3160038	Retaining Ring	ストップリング	1
29	4200155	Thrust Ring	スラストリング	1
30	4200153	Feed Lift Shaft	送り上下軸	1
31	330006	Seal Plug	詰栓	2
32	310118	Oil Wick	油芯	2
33	4200151	Feed Lift Driving Lever	送り上下軸腕	1
34	4200159	Feed Dog Bracket	送り取付台	1
35	110128	Screw (M6-0.75X9)	止ネジ	1
36	150007	Screw (M3-0.5X10)	止ネジ	1
37	000012	Nut	ナット	1
38	4209000	Feed Dog (34.9mm)	送り	1
39	110125	Screw (M5-0.8X7)	止ネジ	2
40	4209200	Loop Deflector	糸受け	2
41	001230	Screw (3/32-56X3.8)	止ネジ	4

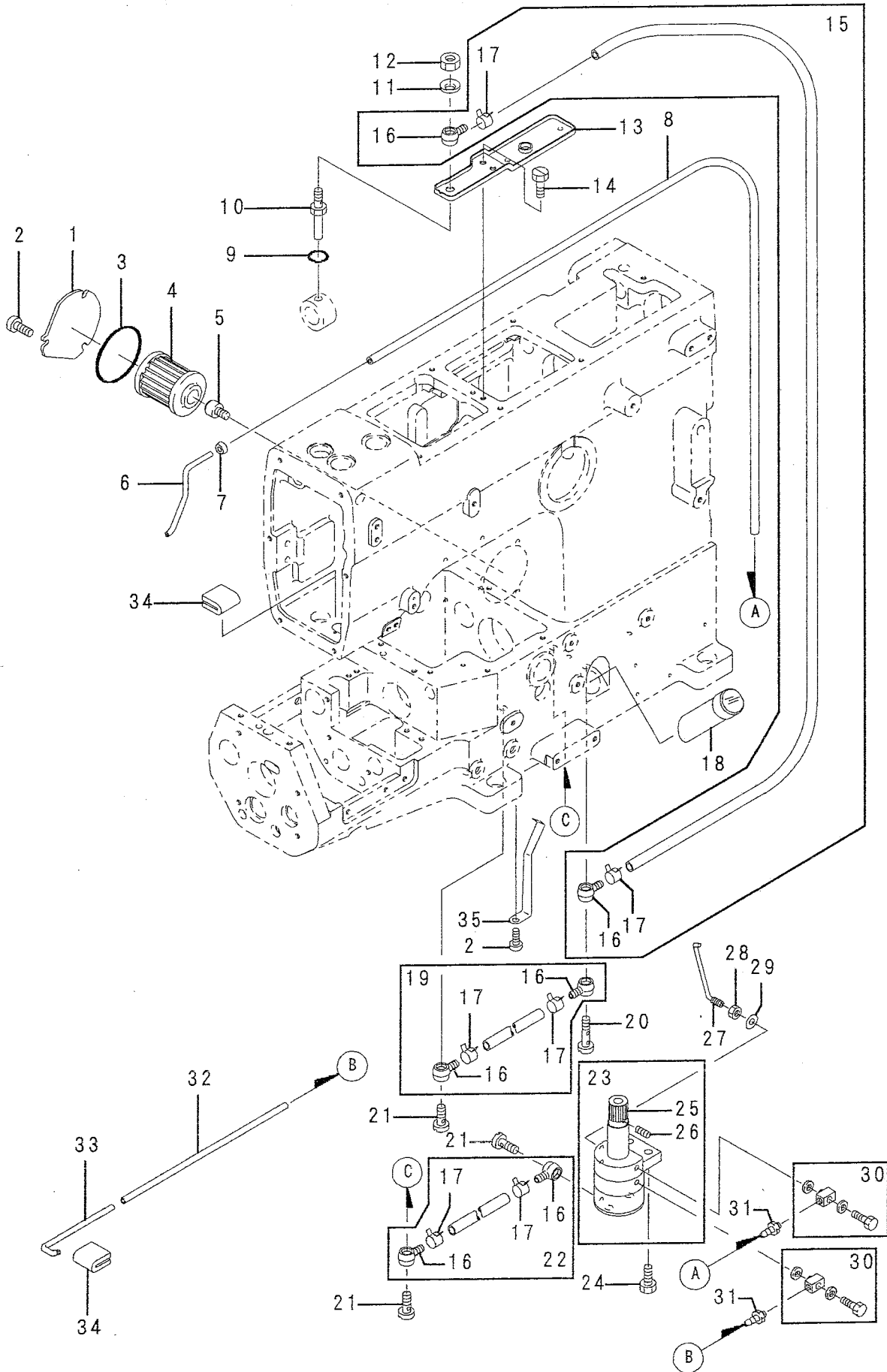

Ref.No.	Parts No.	Description	品名	Amt. Req
1	3500229	Oil Filter Cover	オイルフィルタカバー	1
2	110013	Screw (M4-0.7X8)	止ネジ	4
3	3100061	O Ring (P42)	Oリング	1
4	3100345	Oil Filter	オイルフィルタ	1
5	3100329	Oil Filter Connector	オイルフィルタ継手	1
6	3200236	Suction Pipe	吸入パイプ	1
7	0093617	Suction Pipe Bushing	吸入パイプブッシュ	1
8	4200211	Oil Tube (3X5X500)	オイルパイプ	1
9	0032518	O Ring (P3)	Oリング	1
10	3500402	Oil Sight Top Nozzle	ノズル	1
11	000010	Conical Spring Washer	皿バネワッシャ	1
12	000234	Nut	ナット	1
13	4200199	Oil Reservoir	油受ケ皿	1
14	110012	Screw (M4-0.7X5)	止ネジ	2
15	4200206	Oil Tube, C. Set (4X6X540)	給油パイプ(組)	1
16	3100370	Oil Tube Joint, One Way	片口管継手	6
17	0031831	Oil Tube Clamp	緊束環	6
18	0021010	Oil Sight Gauge	オイルゲージ	1
19	4200208	Oil Tube, C. Set (4X6X85)	給油パイプ(組)	1
20	320009	Fitting Stud (Long)	管継手ボルト(長)	1
21	320008	Fitting Stud (Short)	管継手ボルト(短)	3
22	4200204	Oil Tube, C. Set (4X6X125)	給油パイプ(組)	1
23	3150143	Oil Pump, C. Set	ポンプ(組)	1
24	120013	Screw (M6-1X15)	止ネジ	2
25	0030711	Oil Pump Driving Worm Gear	ウォームギヤ	1
26	160001	Screw (M4-0.7X4)	止ネジ	2
27	4200203	Oil Tube	給油パイプ	1
28	100014	Nut	ナット	1
29	000567	Seal	パッキン	1
30	0010019	Universal Elbow (M5-UL)	ユニバーサルエルボ	2
31	0010017	Pipe Joint (I-4)	パイプ継手	2
32	4200210	Oil Tube (3X5X225)	オイルパイプ	1
33	4200212	Suction Pipe	吸入パイプ	1
34	3100123	Felt	フェルト	2
35	3100330	Oil Tube Stay	オイルパイプ支エ	1

# 13 PULLER MECHANISM (1)

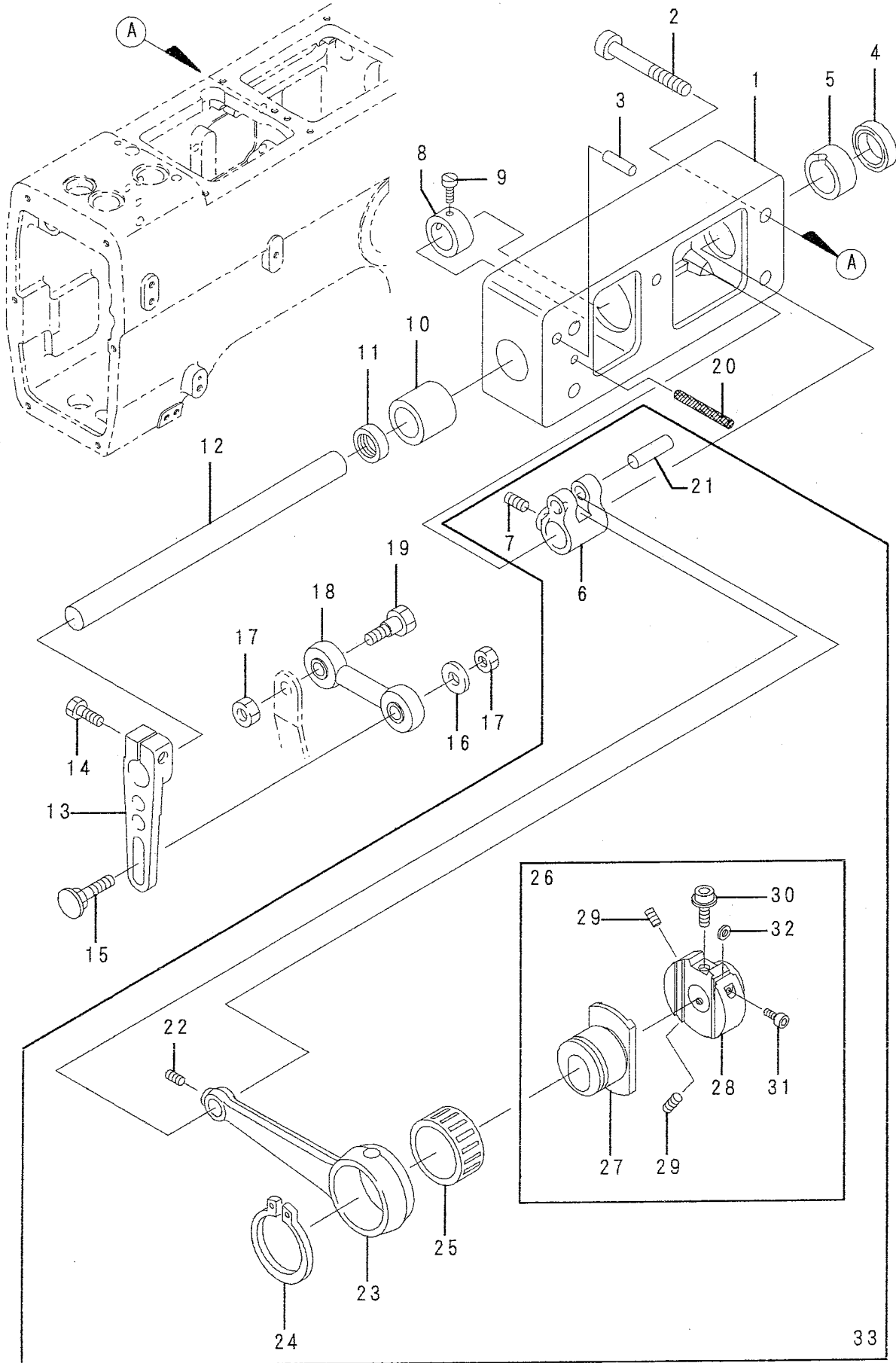

From the library of: Diamond Needle Corp



Ref.No.	Parts No.	Description	品名	Amt. Req
1	4200329	Upper Feed Roller Shaft Bracket	上ローラ軸ブラケット	1
2	120019	Screw (M6-1X18)	止ネジ	4
3	000779	Knock Pin	ノックピン	2
4	3100006	Seal Plug	詰栓	1
5	3100607	Roller Shaft Bushing (Right)	上ローラ軸ブッシュ(右)	1
6	4200324	Upper Feed Roller Shaft Lever	上ローラ軸腕	1
7	160007	Screw (M6-1X6)	止ネジ	2
8	0065398	Collar (14X22X10mm)	カラー	1
9	009604	Screw (11/64-40X5.5)	止ネジ	2
10	3100626	Roller Shaft Bushing (Left)	上ローラ軸ブッシュ(左)	1
11	0065395	Oil Seal	オイルシール	1
12	3100605	Upper Feed Roller Shaft	上ローラ軸	1
13	4200308	Upper Feed Roller Lever	上ローラレバー	1
14	120012	Screw (M6-1X20)	止ネジ	1
15	0065401	Upper Feed Roller Lever Pin	上ローラレバーピン	1
16	000613	Washer	ワッシャ	1
17	000306	Nut	ナット	2
18	3501281	Upper Feed Roller Lever Rod	上ローラレバーロッド	1
19	240010	Screw (1/4-40X11)	止ネジ	1
20	310063	Oil Wick	油芯	1
21	0032921	Upper Feed Roller Driving Rod Pin	上ローラロッドピン	1
22	160001	Screw (M4-0.7X4)	止ネジ	1
23	3100602	Upper Feed Roller Driving Rod	上ローラロッド	1
24	3100192	Retaining Ring	ストップリング	1
25	3100623	Roller Bearing	ニードルベアリング	1
26	3100603	Upper Feed Roller Regulator, C. Set	上ローラ調節器(組)	1
27	3100601	Upper Feed Roller Eccentric	上ローラエキセン	1
28	3100600	Upper Feed Roller Regulator	上ローラ調節器	1
29	160003	Screw (M5-0.8X5)	止ネジ	2
30	190007	Adjusting Screw (M5-0.8X6)	調節ネジ	1
31	120008	Screw (M4-0.7X8)	止ネジ	1
32	300045	Spacer	スペーサ	1
33	4200331	Upper Feed Roller Rod, C. Set 2	上ローラロッド(組2)	1

# 14 PULLER MECHANISM (2)

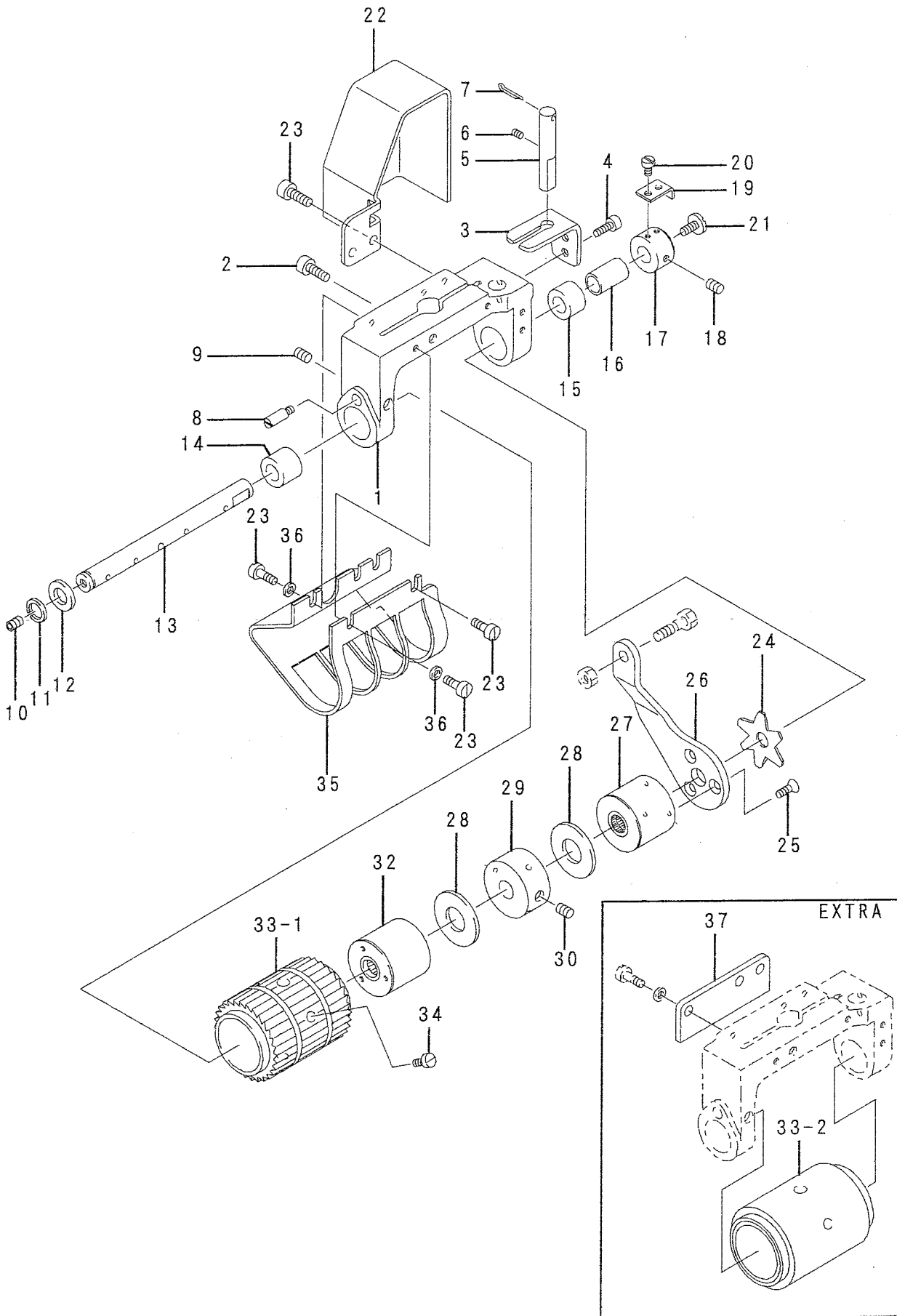

Ref.No.	Parts No.	Description	品名	Amt. Req
1	4200311	Upper Feed Roller Yoke	上ローラヨーク	1
2	120012	Screw (M6-1X20)	止ネジ	1
3	3100612	Upper Feed Roller Yoke Guide	上ローラヨークガイド	1
4	120008	Screw (M4-0.7X8)	止ネジ	2
5	3100613	Upper Feed Roller Yoke Pin	上ローラヨークピン	1
6	160007	Screw (M6-1X6)	止ネジ	1
7	3200133	Wire (0.9X45mm)	鉄線	1
8	180005	Screw (M4-0.7X6)	止ネジ	1
9	160001	Screw (M4-0.7X4)	止ネジ	2
10	160003	Screw (M5-0.8X5)	止ネジ	3
11	0060056	Retaining Ring	ストップリング	1
12	2150075	Thrust Ring	スラストリング	1
13	3501270	Clutch Driving Shaft	クラッチ軸	1
14	3100616	Clutch Driving Shaft Bushing (Left)	クラッチ軸ブッシュ(左)	1
15	0065414	Clutch Driving Shaft Bushing (Right)	クラッチ軸ブッシュ(右)	1
16	0065421	Clutch Tension Sleeve	クラッチテンションスリーブ	1
17	3501283	Adjusting Collar	調節カラー	1
18	160003	Screw (M5-0.8X5)	止ネジ	2
19	3501284	Adjusting Screw Stay	調節ネジ支エ	1
20	110002	Screw (M3-0.5X5)	止ネジ	2
21	110097	Screw (M5-0.8X12)	止ネジ	1
22	4200319	Clutch Driving Lever Cover	クラッチ板カバー	1
23	110041	Screw (M4-0.7X8)	止ネジ	5
24	3501282	Clutch Tension Spring	クラッチテンションバネ	1
25	130003	Screw (M4-0.7X7.3)	止ネジ	3
26	4200309	Clutch Driving Lever (Right)	クラッチ板(右)	1
27	3501276	Clutch Sleeve (Right)	クラッチスリーブ(右)	1
28	3501272	Thrust Plate	スラストプレート	2
29	4200314	Clutch Spacer	クラッチスペーサ	1
30	160005	Screw (M6-1X8)	止ネジ	1
31				
32	3501275	Clutch Sleeve (Left)	クラッチスリーブ(左)	1
33 - 1	4200326	Upper Feed Roller (6teeth) (Standard)	上ローラ(6山)(標準)	1
33 - 2	3501295	Upper Feed Roller (Rubber) (EXTRA)	上ローラ(ゴム)(エキストラ)	1
34	110022	Screw (M3-0.5X10)	止ネジ	3
35	4200320	Upper Feed Roller Cover	上ローラカバー	1
36	000538	Washer	ワッシャ	2
37	4200330	Upper Feed Roller Cover (EXTRA)	上ローラカバー(エキストラ)	1

# 15 PULLER MECHANISM (3)

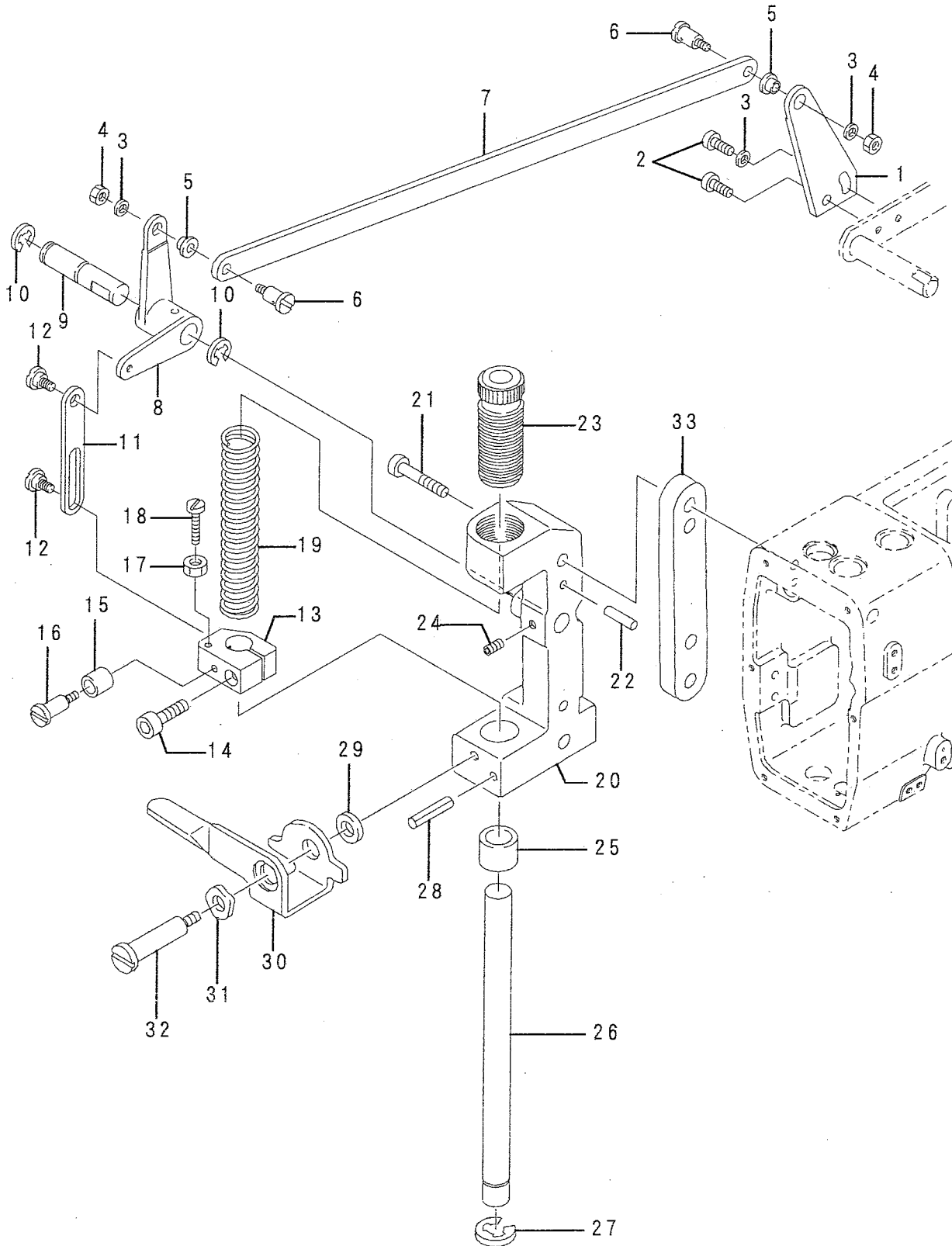

From the library of: Diamond Needle Corp

Ref.No.	Parts No.	Description	品名	Amt. Req
1	0065381	Upper Feed Roller Lifter (Right)	上ローラ揚ゲ(右)	1
2	110047	Screw (M4-0.7X10)	止ネジ	2
3	000538	Washer	ワッシャ	3
4	000334	Nut	ナット	2
5	0034979	Flexible Wire Clamp Bushing	ワイヤ止めブッシュ	2
6	006075	Screw (11/64-40X6)	止ネジ	2
7	4200312	Lifter Connecting Plate	上ローラ揚ゲ連結板	1
8	0065374	Upper Feed Roller Lifter (Left)	上ローラ揚ゲ(左)	1
9	0065375	Upper Feed Roller Lifter Pin	上ローラ揚ゲピン	1
10	0095027	Retaining Ring	ストップリング	2
11	0065376	Lifting Connecting Plate	上ローラ吊り	1
12	006038	Screw (3/16-32X2.2)	止ネジ	2
13	0065407	Roller Press Bar Bracket	上ローラ押エ棒抱キ	1
14	005650	Screw (M5-0.8X14)	止ネジ	1
15	0065402	Lifting Lever Sleeve	上ローラレバースリーブ	1
16	006411	Screw (11/64-40X5.5)	止ネジ	1
17	000340	Nut	ナット	1
18	009931	Stop Screw (11/64-40X26)	ストップパネジ	1
19	3100614	Roller Press Spring	上ローラ押エバネ	1
20	4200328	Upper Feed Roller Bracket	上ローラブラケット	1
21	009964	Screw (M6-1X40)	止ネジ	2
22	000779	Knock Pin	ノックピン	2
23	0065405	Roller Press Bar Bushing (Upper)	上ローラ押エ棒ブッシュ(上)	1
24	160007	Screw (M6-1X6)	止ネジ	1
25	3100609	Roller Press Bar Bushing (Lower)	上ローラ押エ棒ブッシュ(下)	1
26	0065404	Upper Feed Roller Press Bar	上ローラ押エ棒	1
27	0034117	Retaining Ring	ストップリング	1
28	000690	Spring Pin	ストップピン	1
29	000613	Washer	ワッシャ	1
30	0067111	Upper Feed Roller Lifting Lever	手揚ゲ	1
31	000487	Wave Washer	波形ワッシャ	1
32	170008	Screw (M6-1X9)	止ネジ	1
33	4200318	Spacer	スペーサ	1

# 16 PULLER MECHANISM (4)

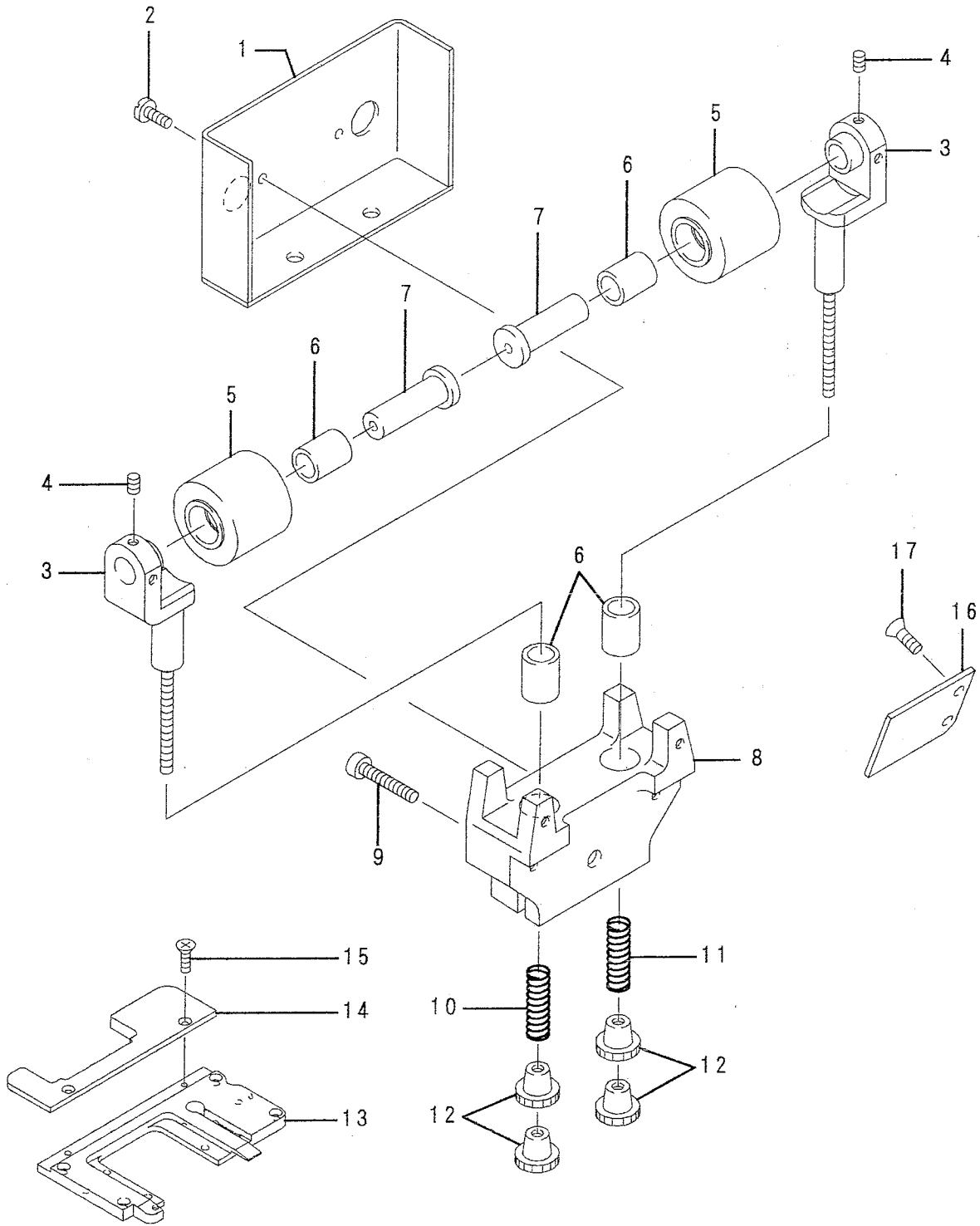

Ref.No.	Parts No.	Description	品名	Amt. Req
1	4200317	Lower Roller Cover	下ローラカバー	1
2	004358	Screw (1/8-44X2.1)	止ネジ	2
3	4200323	Lower Roller Bracket, C. Set	下ローラ取付台(組)	2
4	160001	Screw (M4-0.7X4)	止ネジ	4
5	4200315	Lower Roller	下ローラ	2
6	0066576	Lower Feed Roller Bushing	下ローラブッシュ	4
7	0066575	Lower Feed Roller Pin	下ローラピン	2
8	4200332	Lower Feed Roller Bracket	下ローラブラケット	1
9	120012	Screw (M6-1X20)	止ネジ	2
10	4200322	Lower Roller Bracket Spring (Left)	バネ(左)	1
11	4200321	Lower Roller Bracket Spring (Right)	バネ(右)	1
12	100052	Nut	ナット	4
13	4200313	Stitch Plate Holder (for Puller)	針板取付台	1
14	4200327	Cylinder Cover (Upper)	シリンダカバー(上)	1
15	130021	Screw (M4-0.7X6)	止ネジ	2
16	4200325	Cylinder Cover (Rear)	シリンダカバー(後)	1
17	130002	Screw (M3-0.5X6)	止ネジ	2

17 MG2002

MG2002 -318-X03

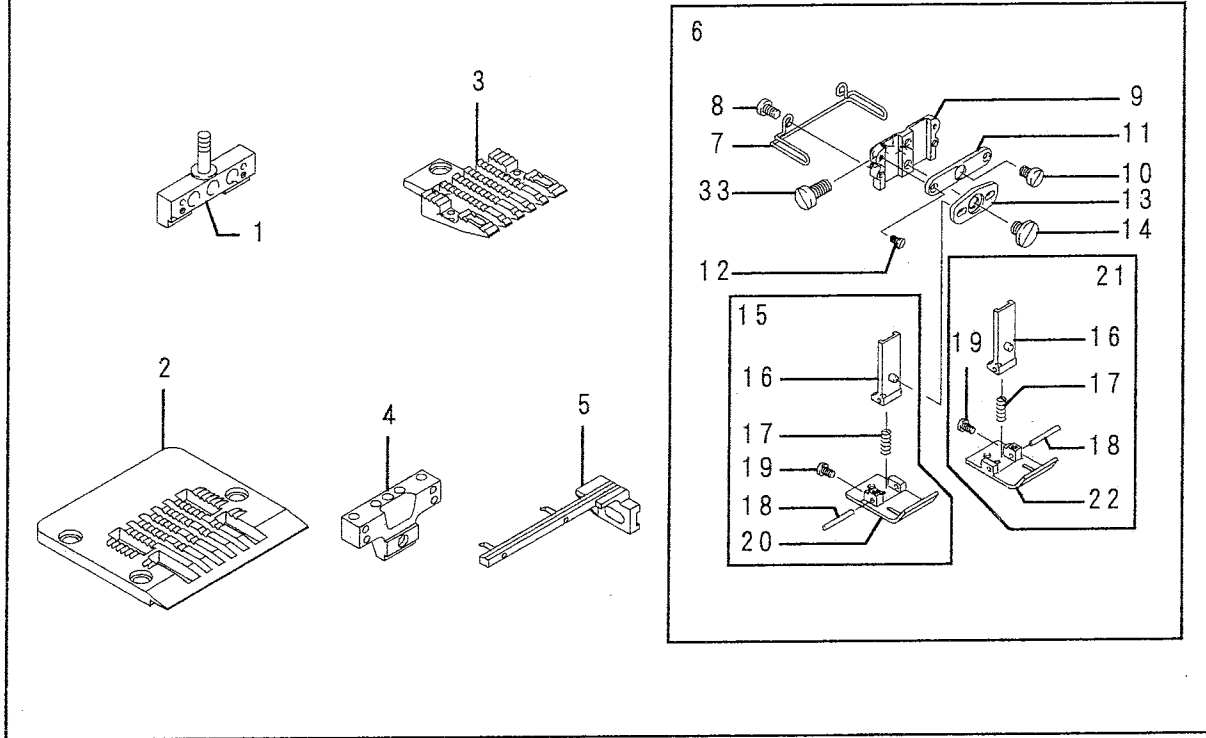

MG2002 -381-X02

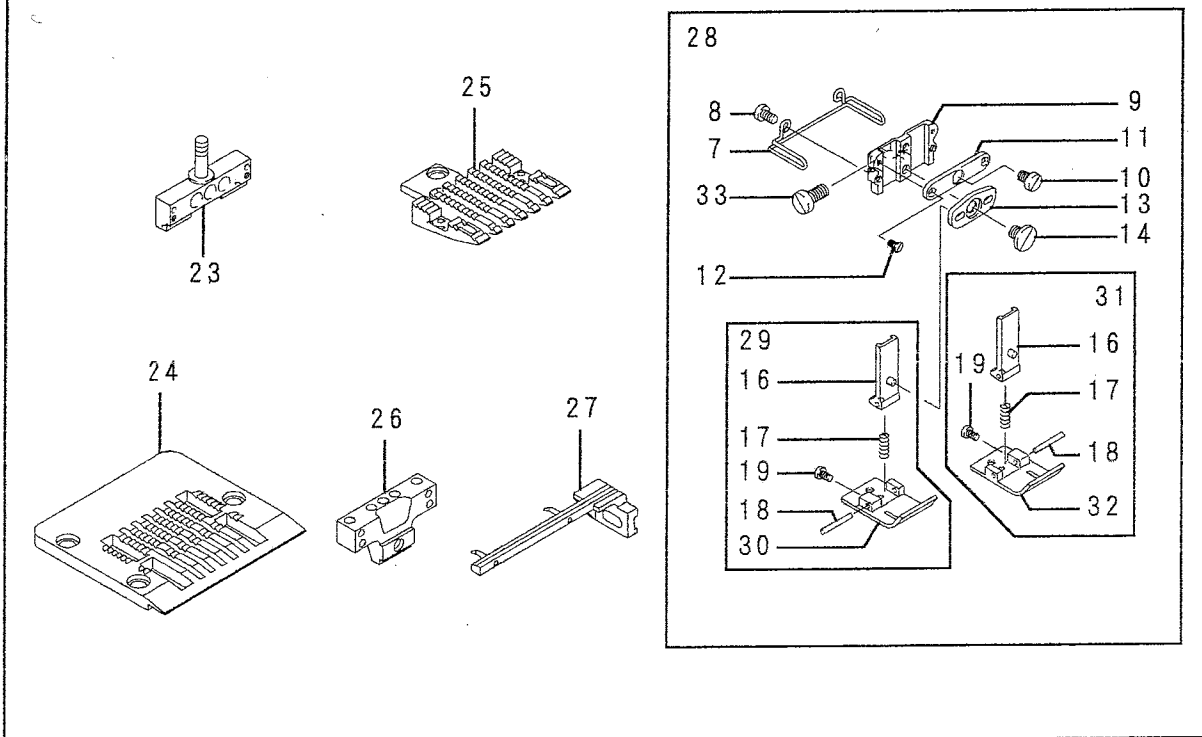



Ref.No.	Parts No.	Description	品名	Amt. Req
1	4209103	Needle Clamp (31.8mm)	針止め	1
2	4208003	Stitch Plate (31.8mm)	針板	1
3	4209003	Feed Dog (31.8mm)	送り	1
4	4209318	Looper Holder (31.8mm)	ルーパ台	1
5	4209309	Retainer (31.8mm)	リテイナ	1
6	4207024	Presser Foot, C. Set (31.8mm)	押エ(組)	1
7	4207010	Finger Guard	フィンガガード	1
8	110003	Screw (M3.5-0.6X6)	止ネジ	2
9	4207002	Presser Foot (Upper)	押エ(上)	1
10	110001	Screw (M4-0.7X5.4)	止ネジ	1
11	4207000	Presser Foot Guide	押エガイド板	1
12	130001	Screw (M2.5-0.45X6)	止ネジ	2
13	4207008	Presser Foot (Lower) Guide	押エ(下)ガイド板	1
14	170053	Screw (M5-0.8X4.5)	止ネジ	1
15	4207022	Presser Foot (Left), C. Set (31.8mm)	押エ下(左)(組)	1
16	4207001	Presser Foot (Lower) Guide	押エ(下)ガイド	1
17	4207011	Presser Foot (Lower) Spring	押エ下バネ	1
18	0034053	Pin	ピン	1
19	110084	Screw (M3-0.5X4.2)	止ネジ	1
20	4207020	Presser Foot (Left) (31.8mm)	押エ下(左)	1
21	4207023	Presser Foot (Right), C. Set (31.8mm)	押エ下(右)(組)	1
22	4207021	Presser Foot (Right) (31.8mm)	押エ下(右)	1
23	4209104	Needle Clamp (38.1mm)	針止め	1
24	4208004	Stitch Plate (38.1mm)	針板	1
25	4209004	Feed Dog (38.1mm)	送り	1
26	4209319	Looper Holder (38.1mm)	ルーパ台	1
27	4209311	Retainer (38.1mm)	リテイナ	1
28	4207029	Presser Foot (38.1mm), C. Set	押エ(組)	1
29	4207027	Presser Foot (Left), C. Set (38.1mm)	押エ下(左)(組)	1
30	4207025	Presser Foot (Left) (38.1mm)	押エ下(左)	1
31	4207028	Presser Foot (Right), C. Set (38.1mm)	押エ下(右)(組)	1
32	4207026	Presser Foot (Right) (38.1mm)	押エ下(右)	1
33	110011	Screw (M5-0.8X10)	止ネジ	1

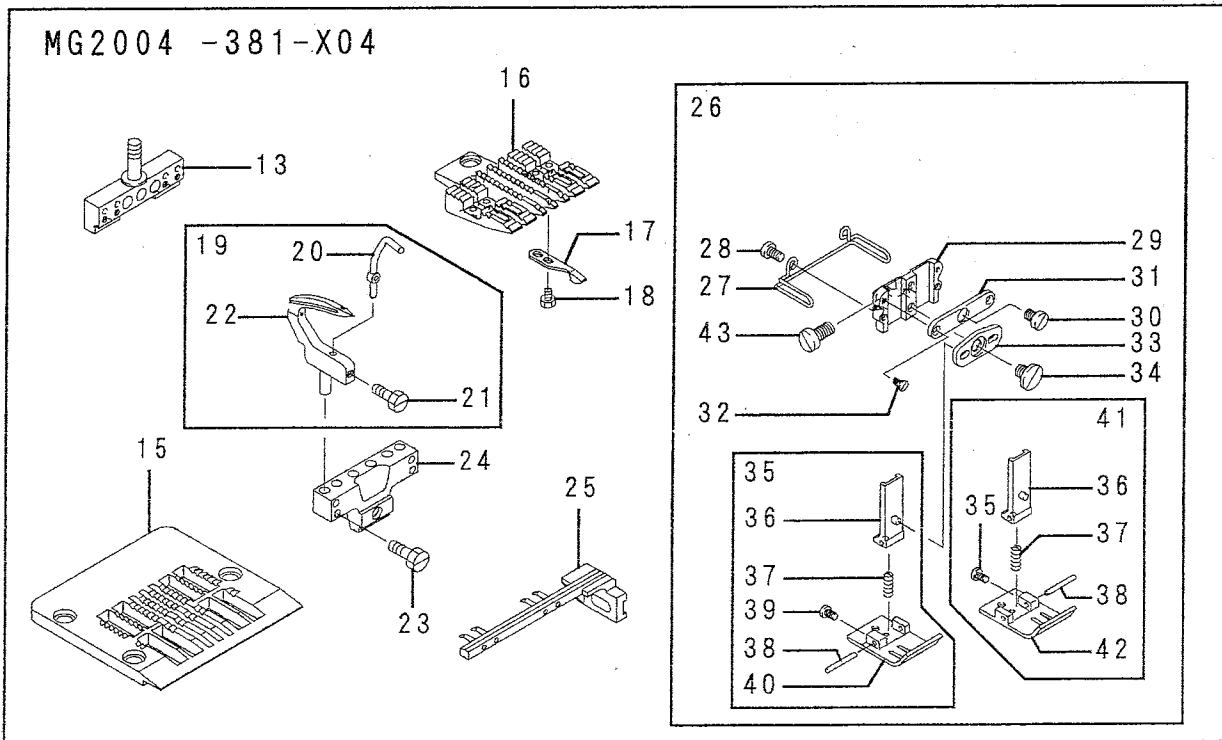
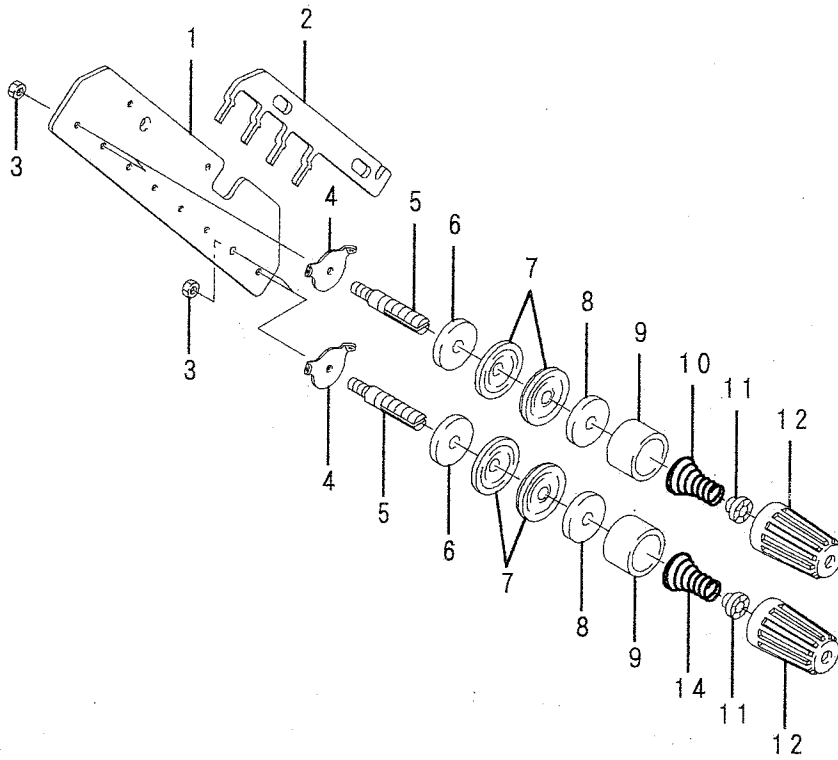

Ref.No.	Parts No.	Description	品名	Amt. Req
1	4200056	Tension Post Plate	糸調子台	1
2	4200057	Tension Release Plate	糸緩メ板	1
3	000015	Nut	ナット	7
4	0020101	Tension Disc Eyelet	糸調子皿糸道	8
5	190016	Tension Post	糸調子棒	8
6	000613	Washer	ワッシャ	8
7	0031111	Tension Disc	糸調子皿	16
8	000177	Felt	フェルト	8
9	0020118	Thread Tension Spring Retainer	糸調子バネキャップ(下)	8
10	2150136	Tension Spring (Needle)	糸調子バネ(針)	4
11	0024083	Tension Spring Bushing	回り止メ	8
12	0024084	Thread Tension Spring Cap	糸調子バネキャップ(上)	8
13	4209101	Needle Clamp (1/4-1-1/4)	針止メ	1
14	0090847	Tension Spring (Looper)	糸調子バネ(ルーパ)	4
15	4208001	Stitch Plate (1/4-1-1/4)	針板	1
16	4209001	Feed Dog (1/4-1-1/4)	送り	1
17	4209200	Loop Deflector	糸受ケ	4
18	001230	Screw (3/32-56X3.8)	止ネジ	2
19	4209326	Looper Needle Guard, C. Set	ルーパ・針受ケ(組)	4
20	4209201	Needle Guard (Rear)	針受ケ(後)	4
21	120056	Screw (M3-0.5X5)	止ネジ	4
22	4209325	Looper	ルーパ	4
23	110126	Screw (M3-0.5X7)	止ネジ	4
24	4209316	Looper Holder (1/4-1-1/4)	ルーパ台	1
25	4209305	Retainer (34.9mm)	リテイナ	1
26	4207019	Presser Foot, C. Set (1/4-1-1/4)	押エ(組)	1
27	4207010	Finger Guard	フィンガガード	1
28	110003	Screw (M3.5-0.6X6)	止ネジ	2
29	4207002	Presser Foot (Upper)	押エ(上)	1
30	110001	Screw (M4-0.7X5.4)	止ネジ	1
31	4207000	Presser Foot Guide	押エガイド板	1
32	130001	Screw (M2.5-0.45X6)	止ネジ	2
33	4207008	Presser Foot (Lower) Guide	押エ(下)ガイド板	1
34	170053	Screw (M5-0.8X4.5)	止ネジ	1
35	4207017	Presser Foot (Left), C. Set (1/4-1-1/4)	押エ下(左)(組)(1/4-1-1/4)	1
36	4207001	Presser Foot (Lower) Guide	押エ(下)ガイド	1
37	4207011	Presser Foot (Lower) Spring	押エ下バネ	1
38	0034053	Pin	ピン	1
39	110084	Screw (M3-0.5X4.2)	止ネジ	1
40	4207015	Presser Foot (Left) (1/4-1-1/4)	押エ下(左)(1/4-1-1/4)	1
41	4207018	Presser Foot (Right), C. Set (1/4-1-1/4)	押エ下(右)(組)(1/4-1-1/4)	1
42	4207016	Presser Foot (Right) (1/4-1-1/4)	押エ下(右)(1/4-1-1/4)	1
43	110011	Screw (M5-0.8X10)	止ネジ	1

# 19 "FL10" DEVICE

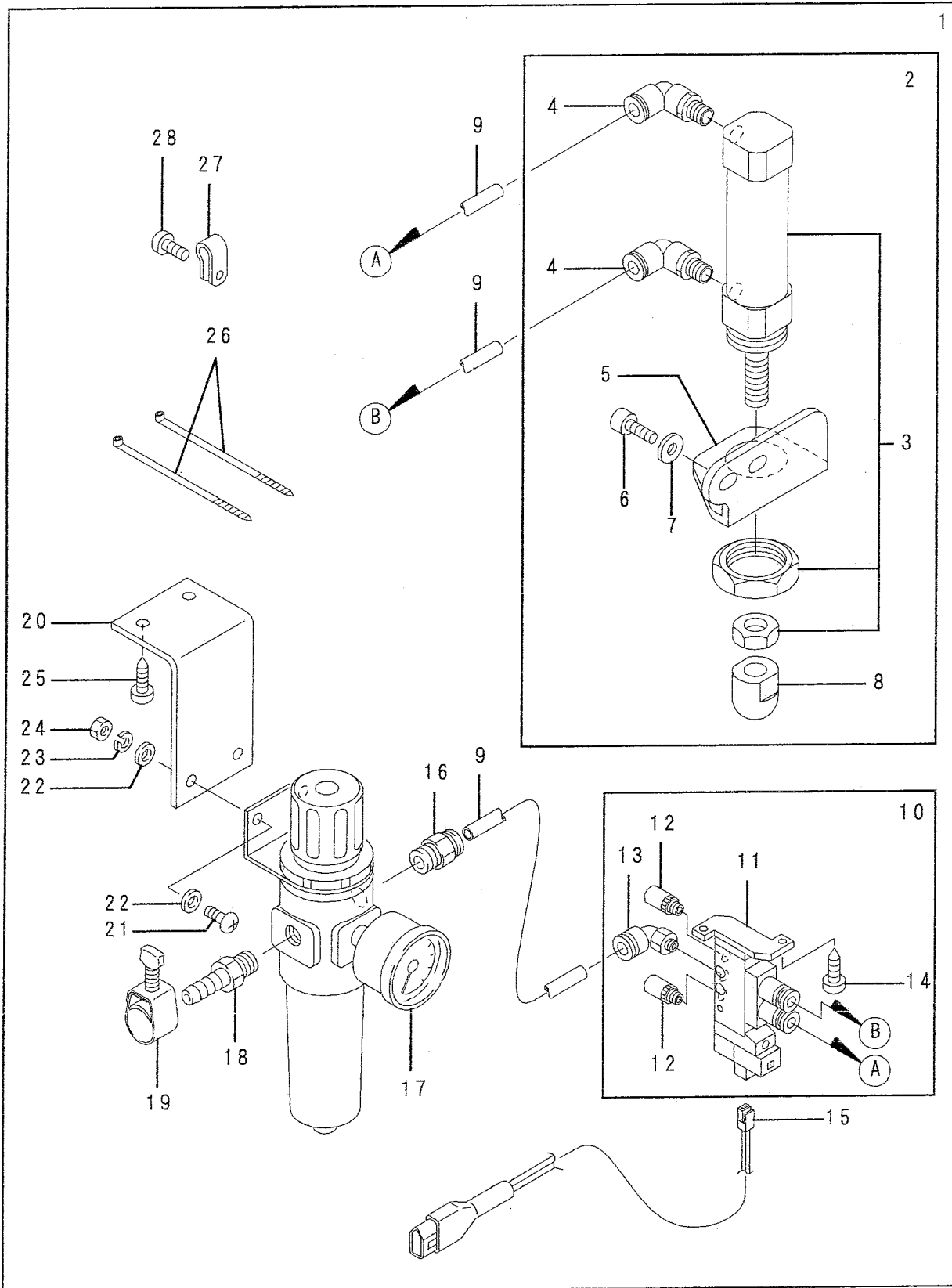

Ref.No.	Parts No.	Description	品名	Amt. Req
1	4201002	"FL10" Device, C. Set	"FL10"装置(組)	1
2	4201000	Air Cylinder, C. Set	押工場ゲシリンダ(組)	1
3	1091162	Air Cylinder (CM2BZ225-35-XA0)	押工場ゲシリンダ	1
4	0010266	Elbow Connector (EL6-PT1/8)	エルボコネクタ 1/8	2
5	3500505	Cylinder Bracket	シリンダ台	1
6	120013	Screw (M6-1X15)	止ネジ	2
7	000425	Washer	ワッシャ	2
8	3201037	Cylinder Rod Chip	シリンダロッドチップ	1
9	1096025	Air Tube (6X4mm) White	エアチューブ	3
10	1090239	Solenoid Valve, C. Set	電磁弁(組)	1
11	1090238	Solenoid Valve (SY3120-5LOU-C6-F)	電磁弁	1
12	0010066	Silencer (AN120-M5)	サイレンサ	2
13	1094063	Elbow Connector (KJL06-M5)	エルボコネクタ M5	1
14	006203	Wood Screw (Ø2.4X16)	木ネジ	2
15	1200385	Solenoid Valve Cord	電磁弁用コード	1
16	0010264	Connector (EC6-PT1/4)	継手	1
17	0010073	Regulator (AW2000)	レギュレータ	1
18	0010108	Hose Union (NH-512-8X1/4)	ホースユニオン	1
19	0033939	Hose Band	ホースバンド	1
20	0013218	Regulator Support	レギュレータ取付板	1
21	009960	Screw (M5-0.8X16)	止ネジ	2
22	000669	Washer	ワッシャ	4
23	000600	Spring Washer	スプリングワッシャ	2
24	000009	Nut	ナット	2
25	350013	Wood Screw (Ø5.1X16)	木ネジ	2
26	0011795	Wrapping Band	束線バンド	3
27	0010291	Cord Clamp (8N-Ø13.2)	コードクランプ	1
28	110013	Screw (M4-0.7X8)	止ネジ	1



Ref.No.	Parts No.	Description	品名	Amt. Req
1 - 1	9620694	Thread Stand, C. Set (4 Spools Type)	糸立台(組)(4本糸用)	1
1 - 2	9620699	Thread Stand, C. Set (9 Spools Type)	糸立台(組)(9本糸用)	1
2	9620631	Column Cap	コラムキャップ	1
3	9620670	Column Pipe (Upper)	コラムパイプ(上)	1
4	9620689	Thread Guide Holder (Large)	ガイドホルダ(大)	2
5	911002	Screw (M4-0.7X20)	止ネジ	2
6	911001	Screw (M4-0.7X12)	止ネジ	6
7	910001	Nut	ナット	8
8	9620673	Column Pipe Connector	コラムパイプ継手	2
9	911006	Screw (M5-0.8X13)	止ネジ	4
10	910000	Nut	ナット	6 (13)
11	9620675	Column Pipe (Lower)	コラムパイプ(下)	1
12	930052	Washer	ワッシャ	1
13	930053	Spring Washer	スプリングワッシャ	1
14	910003	Nut	ナット	1
15	9620702	Thread Hanger (2 Spools Type)	スレッドハンガ(2本糸用)	2
16	9620703	Thread Hanger (3 Spools Type)	スレッドハンガ(3本糸用)	5
17	9620700	Thread Eyelet	アイレット	4 (9)
18	9620688	Thread Hanger Holder	スレッドハンガ抱キ	4 (5)
19	911060	Screw (M6-1X15)	止ネジ	4 (5)
20	9620691	Thread Guide Arm	ガイドアーム	2
21	9620690	Thread Guide Holder (Small)	ガイドホルダ(小)	2
22	9620665	Thread Guide (5 Spools Type)	スレッドガイド(5本糸用)	1
23	9620678	Spool Cushion	スプールクッション	4 (9)
24	9620679	Spool Pin	スプール軸	4 (9)
25	9620680	Spool Mat	スプールマット	4 (9)
26	9620681	Spool Seat Disc	受け皿	4 (9)
27	930055	Spring Washer	スプリングワッシャ	4 (9)
28	6920660	Column Pipe (Short) (206mm)	コラムパイプ(短)	1
29	9620668	Thread Guide (8 Spools Type)	スレッドガイド(8本糸用)	1

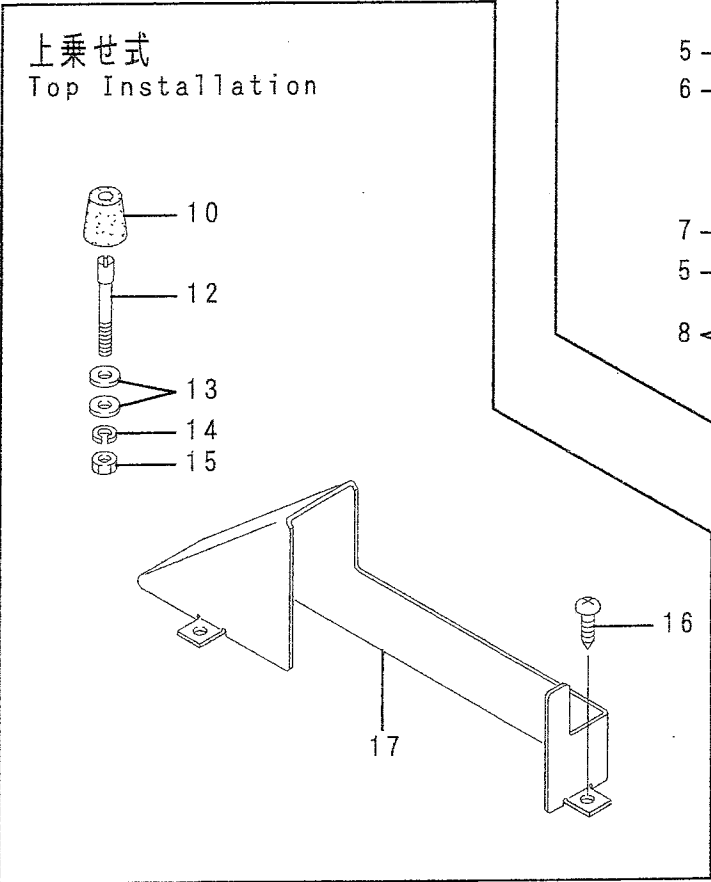
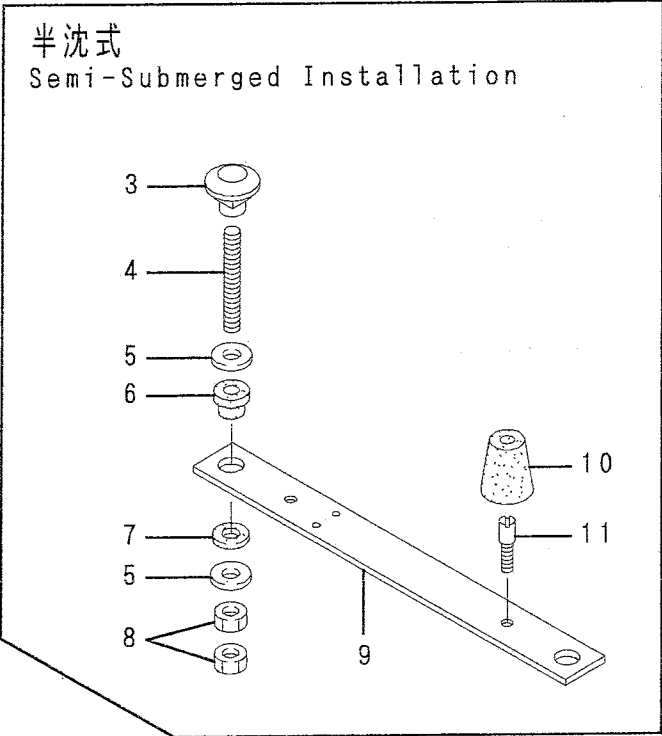
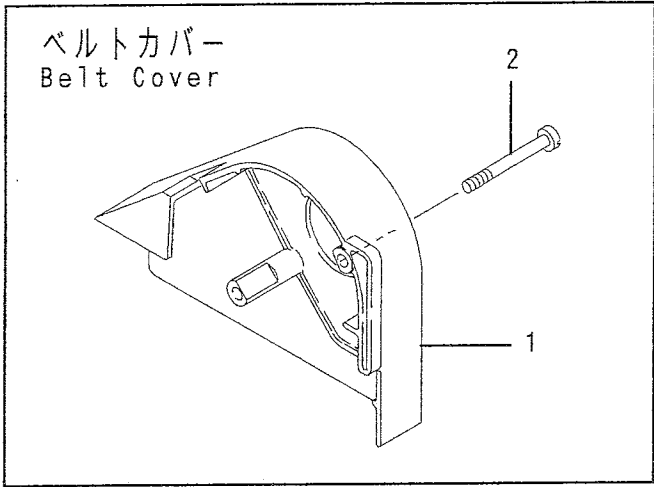



Ref.No.	Parts No.	Description	品名	Amt. Req
1	4200220	Belt Cover	ベルトカバー	1
2	110028	Screw (M6-1X63)	止ネジ	2
3	000070	Hanging Nut	吊リナット	4
4	009858	Hanging Bolt (M8-1.25X75)	吊リボルト	4
5	000162	Washer	ワッシャ	8
6	0020064	Supporting Board Rubber Cushion	受け板ゴム座	4
7	0063010	Supporting Board Rubber Cushion (Lower)	受け板ゴム座(下)	4
8	000016	Nut	ナット	8
9	3100008	Supporting Board	油受け板	2
10	0063009	Oil Reservoir Rubber Cushion	ゴム座	4
11	180009	Setting Screw (M6-1X16)	取付ケネジ	4
12	180008	Setting Screw (M6-1X63)	取付ケネジ	4
13	000528	Washer	ワッシャ	8
14	000667	Spring Washer	スプリングワッシャ	4
15	000011	Nut	ナット	4
16	006905	Wood Screw (Ø5.1X20)	木ネジ	3
17	3100036	Belt Cover (Lower)	ベルトカバー(下)	1

# 22 EXTRA PARTS(1)

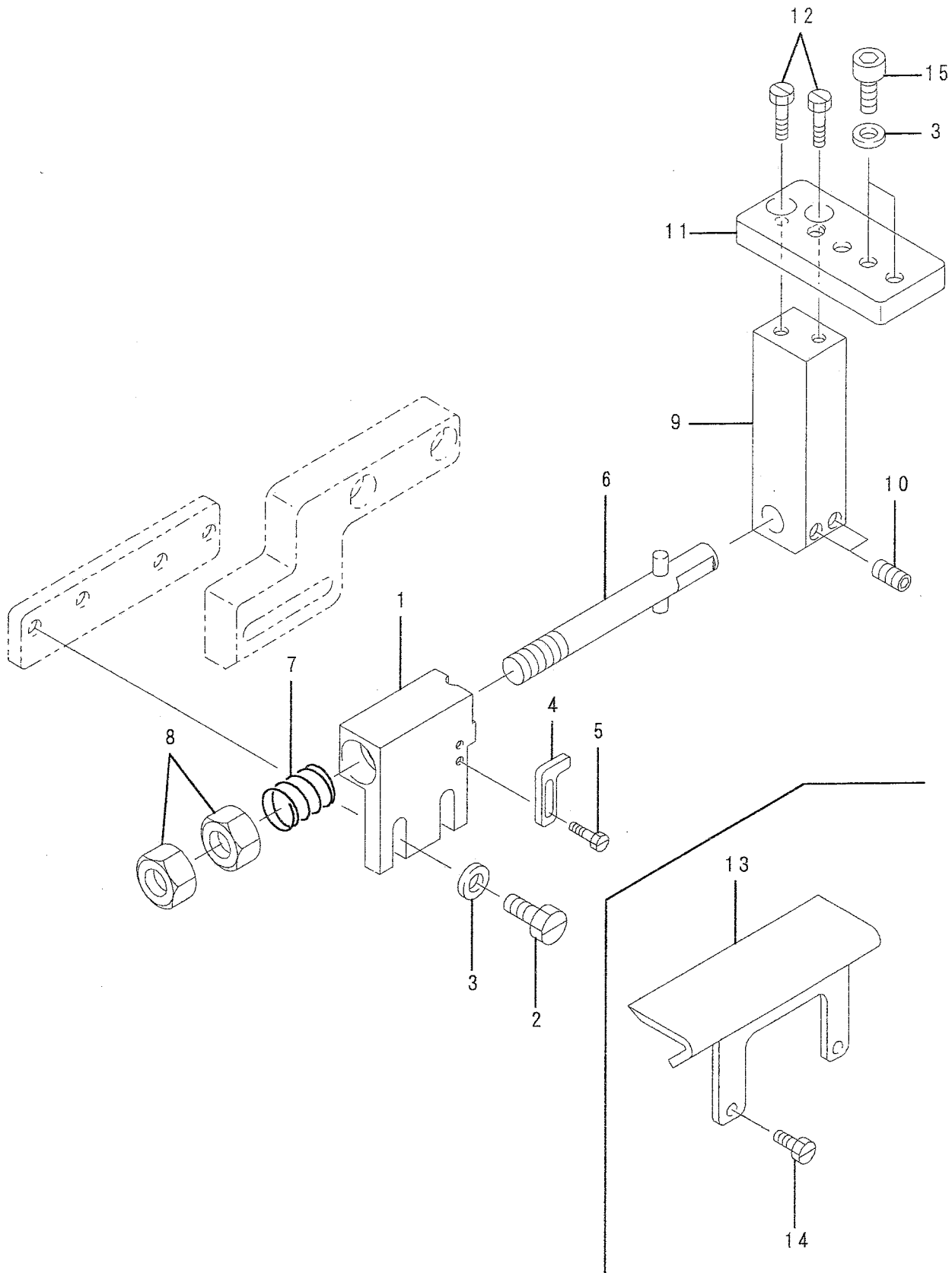



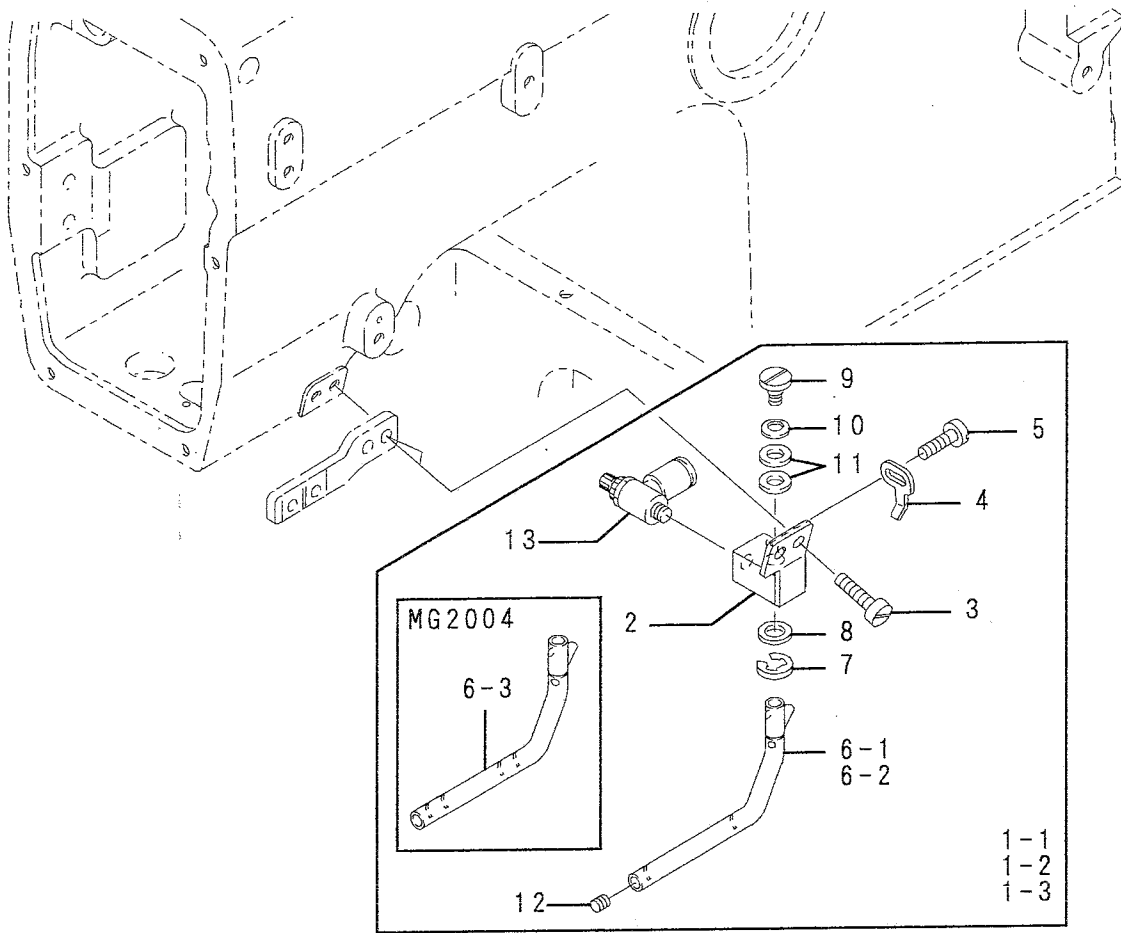

From the library of: Diamond Needle Corp

Ref.No.	Parts No.	Description	品名	Amt. Req
1	4200303	Folder Bracket 4	定規台4	1
2	009976	Screw (M6-1X15)	止ネジ	2
3	300011	Washer	ワッシャ	4
4	4200304	Stopper	ストッパ	1
5	110002	Screw (M3-0.5X5)	止ネジ	2
6	4200307	Folder Bracket Shaft	定規台軸	1
7	0092292	Spring	バネ	1
8	000054	Nut	ナット	2
9	4200306	Folder Bracket 5	定規台5	1
10	160007	Screw (M6-1X6)	止ネジ	2
11	4200302	Folder Bracket 3	定規台3	1
12	009751	Screw (M5-0.8X10)	止ネジ	2
13	4200058	Supplementary Cover	補助カバー	1
14	110001	Screw (M4-0.7X5.4)	止ネジ	2
15	120010	Screw (M6-1X10)	止ネジ	2

# 23 EXTRA PARTS(2)

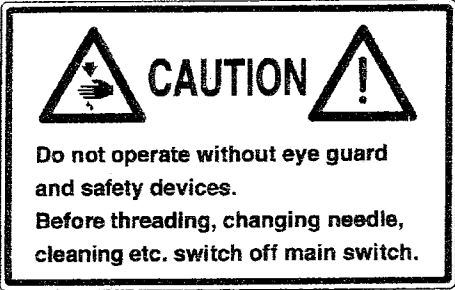
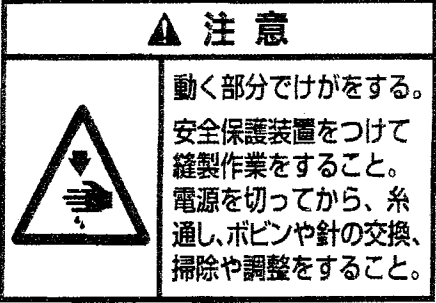
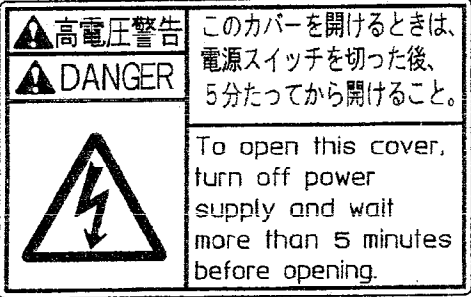

Ref.No.	Parts No.	Description	品名	Amt. Req
1 - 1	4201019	Needle Cooler Device, C. Set (for MG2002 31.8mm)	針冷却装置(組)	1
1 - 2	4201010	Needle Cooler Device, C. Set (for MG2002 34.9&38.1mm)	針冷却装置(組)	1
1 - 3	4201017	Needle Cooler Device, C. Set (for MG2004 1/4-1-1/4)	針冷却装置(組)	1
2	4201014	Air Pipe Bracket, C. Set	エアパイプ取付台(組)	1
3	110035	Screw (M4-0.7X10)	止ネジ	2
4	4201015	Air Pipe Set Plate	エアパイプ位置決め板	1
5	110084	Screw (M3-0.5X4.2)	止ネジ	2
6 - 1	4201020	Air Pipe (for MG2002 31.8mm)	エアパイプ	1
6 - 2	4201011	Air Pipe (for MG2002 34.9 & 38.1mm)	エアパイプ	1
6 - 3	4201018	Air Pipe (for MG2004 1/4-1-1/4)	エアパイプ	1
7	2100444	Retaining Ring	ストップリング	1
8	000399	Washer	ワッシャ	1
9	170009	Screw (M4-0.7X4)	止ネジ	1
10	000172	Conical Spring Washer	皿バネワッシャ	1
11	000669	Washer	ワッシャ	2
12	160001	Screw (M4-0.7X4)	止ネジ	1
13	1095002	Speed Controller	スピコン	1

LABEL ラベル	Parts.No. 品番	Description 品名
 <p>Do not operate without eye guard and safety devices. Before threading, changing needle, cleaning etc. switch off main switch.</p>	390140	CAUTION IN OPERATION
 <p>▲ 注意 動く部分でけがをする。 安全保護装置をつけて縫製作業をすること。 電源を切ってから、糸通し、ボビンや針の交換、掃除や調整をすること。</p>	390143	操作注意ラベル
 <p>▲ 高電圧警告 ▲ DANGER このカバーを開けるときは、電源スイッチを切った後、5分たってから開けること。 To open this cover, turn off power supply and wait more than 5 minutes before opening.</p>	390144	DANGER : WARNING OF ELECTRIC SHOCK BY HIGH-VOLTAGE 感電注意ラベル
	390145	"Be sure to connect earth line." アースラベル
	390190	ROTATING-DIRECTION SYMBOL : CHECK CORRECT ROTATING DIRECTION 回転方向表示ラベル
 <p>ケガ注意 CAUTION</p>	390147	EYE GUARD : TAKE CARE NOT CAUSE INJURY TO EYES BELT COVER: DO NOT INSERT FINGERS ケガ注意ラベル
 <p>高温注意 CAUTION</p>	390148	CAUTION FOR HIGH TEMPERATURE : DO NOT TOUCH STEPPING MOTOR AND SOLENOID 高温注意ラベル

## MG2000 CLASS LIST OF MAIN SPARE PARTS(主要部品リスト)

Main Parts Models	Needle Clamp	Presser Foot, C. Set	Stitch Plate	Feed Dog	Retainer
	針止メ	押エ(組)	針板	送り	リテイナ
MG2002□-349-X01	4209100	4207007	4208000	4209000	4209301
MG2002□-381-X02	4209104	4207029	4208004	4209004	4209311
MG2002□-318-X03	4209103	4207024	4208003	4209003	4209309
MG2004□-381-X04	4209101	4207019	4208001	4209001	4209305

Main Parts Models	Looper	Looper Holder	Needle Guard (Rear)	Loop Deflector
	ルーパ	ルーパ台	針受ケ(後)	糸受ケ
MG2002□-349-X01	4209325(2)	4209315	4209201(2)	4209200(2)
MG2002□-381-X02	4209325(2)	4209319	4209201(2)	4209200(2)
MG2002□-318-X03	4209325(2)	4209318	4209201(2)	4209200(2)
MG2004□-381-X04	4209325(4)	4209316	4209201(4)	4209200(4)

INDEX

Parts No.	Page No.	Ref. No.	Weight (g)	Parts No.	Page No.	Ref. No.	Weight (g)	Parts No.	Page No.	Ref. No.	Weight (g)
000009	19	24		005650	10	36		0031831	12	17	
000010	2	55		005650	15	14					
000010	12	11						0032518	12	9	
000011	21	15		006038	15	12		0032684	4	19	
000012	11	37		006075	15	6		0032921	11	20	
000015	3	7		006202	2	19		0032921	13	21	
000015	18	3		006203	19	14		0032952	3	17	
000016	21	8		006411	15	16					
000054	22	8		006905	21	16		0033024	2	47	
000070	21	3						0033939	19	19	
000162	21	5		007627	2	33					
000172	23	10						0034053	17	18	
000177	3	12		009604	13	9		0034053	18	38	
000177	18	8		009751	22	12		0034117	8	2	
000206	10	56		009858	21	4		0034117	15	27	
000234	12	12		009931	15	18		0034979	15	5	
000290	7	12		009960	19	21					
000306	13	17		009964	15	21		0035226	3	10	
000309	5	30		009972	9	28					
000334	15	4		009976	3	36		0060056	14	11	
000340	15	17		009976	22	2					
000392	6	20						0063009	21	10	
000399	23	8		0010017	12	31		0063010	21	7	
000425	19	7		0010019	12	30					
000445	10	2		0010066	19	12		0065374	15	8	
000487	10	48		0010073	19	17		0065375	15	9	
000487	15	31		0010108	19	18		0065376	15	11	
000528	9	34		0010264	19	16		0065381	15	1	
000528	21	13		0010266	19	4		0065395	13	11	
000538	3	21		0010291	19	27		0065398	13	8	
000538	14	36						0065401	13	15	
000538	15	3		0011795	19	26		0065402	15	15	
000567	12	29						0065404	15	26	
000600	19	23		0013218	19	20		0065405	15	23	
000613	3	14						0065407	15	13	
000613	13	16		0020052	2	61		0065414	14	15	
000613	15	29		0020064	21	6		0065421	14	16	
000613	18	6		0020101	3	16					
000629	2	27		0020101	18	4		0066575	16	7	
000629	9	38		0020118	3	11		0066576	16	6	
000637	11	24		0020118	18	9		0066650	3	18	
000667	21	14		0020137	1	24					
000669	19	22		0020759	1	8		0067111	15	30	
000669	23	11		0020759	2	59					
000690	15	28						0068011	1	9	
000726	1	16		0021010	12	18		0068181	10	38	
000740	7	19						0068374	2	6	
000779	2	3		0022836	1	25					
000779	13	3		0022837	1	26		0077270	10	1	
000779	15	22									
				0024083	3	9		0090351	11	9	
001230	11	41		0024083	18	11		0090847	18	14	
001230	18	18		0024084	3	8					
001900	9	20		0024084	18	12		0092292	22	7	
004176	7	23		0030291	4	4		0093090	6	1	
004358	16	2		0030711	12	25		0093212	5	28	
004441	10	7						0093214	5	25	
				0031111	3	13		0093483	10	6	
005075	1	23		0031111	18	7					



# INDEX

Parts No.	Page No.	Ref. No.	Weight (g)	Parts No.	Page No.	Ref. No.	Weight (g)	Parts No.	Page No.	Ref. No.	Weight (g)
0093611	10	10		110048	1	3		160000	6	13	
0093617	12	7		110049	3	27		160000	11	23	
0093864	1	4		110049	9	13		160001	2	39	
				110067	5	23		160001	8	15	
0094201	2	28		110070	6	30		160001	9	29	
				110084	10	26		160001	10	12	
0095027	7	32		110084	17	19		160001	12	26	
0095027	11	18		110084	18	39		160001	13	22	
0095027	15	10		110084	23	5		160001	14	9	
				110097	14	21		160001	16	4	
100001	2	36		110116	11	8		160001	23	12	
100014	12	28		110125	9	23		160002	7	17	
100041	8	8		110125	11	39		160003	6	23	
100041	9	33		110126	7	26		160003	7	2	
100052	16	12		110126	18	23		160003	8	5	
				110127	7	3		160003	9	26	
110001	3	29		110128	11	35		160003	11	2	
110001	10	19						160003	13	29	
110001	17	10		120001	10	41		160003	14	10	
110001	18	30		120006	7	22		160003	14	18	
110001	22	14		120006	10	54		160004	5	17	
110002	14	20		120008	13	31		160004	6	21	
110002	22	5		120008	14	4		160005	5	2	
110003	10	32		120010	10	46		160005	6	8	
110003	17	8		120010	22	15		160005	14	30	
110003	18	28		120011	11	4		160007	5	7	
110009	3	20		120012	13	14		160007	6	3	
110009	5	13		120012	14	2		160007	7	21	
110009	7	11		120012	16	9		160007	9	3	
110009	8	11		120013	7	16		160007	11	13	
110011	5	21		120013	9	36		160007	13	7	
110011	10	17		120013	11	26		160007	14	6	
110011	17	33		120013	12	24		160007	15	24	
110011	18	43		120013	19	6		160007	22	10	
110012	1	19		120016	1	20		160020	11	6	
110012	2	29		120018	2	45		160021	11	27	
110012	12	14		120018	6	12		160024	5	33	
110013	2	17		120019	13	2		160029	5	22	
110013	3	2		120047	2	49		160031	5	19	
110013	5	4		120049	2	35		160037	7	9	
110013	12	2		120055	9	17					
110013	19	28		120056	7	28		170001	2	40	
110016	2	38		120056	18	21		170008	15	32	
110021	9	9						170009	10	43	
110021	10	55		130001	10	20		170009	23	9	
110022	14	34		130001	17	12		170018	3	4	
110028	21	2		130001	18	32		170032	2	54	
110030	9	6		130002	2	14		170038	10	44	
110030	11	16		130002	7	14		170041	10	9	
110032	2	9		130002	16	17		170053	10	22	
110035	2	2		130003	6	15		170053	17	14	
110035	10	5		130003	14	25		170053	18	34	
110035	23	3		130006	3	6					
110038	2	53		130021	16	15		180002	6	29	
110041	2	31						180003	6	24	
110041	3	31		140010	8	19		180005	2	42	
110041	14	23						180005	14	8	
110045	1	10		150007	11	36		180008	21	12	
110047	15	2						180009	21	11	
110048	1	27		160000	2	12					

# INDEX

Parts No.	Page No.	Ref. No.	Weight (g)	Parts No.	Page No.	Ref. No.	Weight (g)	Parts No.	Page No.	Ref. No.	Weight (g)
190005	2	58		1094063	19	13		3100616	14	14	
190007	13	30						3100623	13	25	
190015	1	13		1095002	23	13		3100626	13	10	
190016	3	15									
190016	18	5		1096025	19	9		3150143	12	23	
190078	2	4									
				1200385	19	15		3160038	11	28	
240010	13	19									
				2049401	1	17		3200112	5	27	
300000	7	24						3200133	14	7	
300005	10	47		2100137	8	4		3200236	12	6	
300011	3	35		2100161	7	30					
300011	22	3		2100194	10	51		3201037	19	8	
300045	13	32		2100267	10	34					
300100	2	41		2100443	10	11		3500012	2	62	
				2100444	23	7		3500041	4	2	
								3500046	4	1	
310063	13	20		2110361	10	49		3500054	5	5	
310117	9	4		2110566	6	22		3500062	5	18	
310118	11	32						3500229	12	1	
310119	11	7		2150069	4	22		3500291	10	45	
310120	5	24		2150075	7	31		3500293	10	35	
310121	5	16		2150075	14	12		3500294	10	37	
				2150136	18	10		3500295	10	53	
320008	12	21						3500299	10	42	
320009	12	20		3100004	1	21		3500300	10	33	
				3100005	1	22		3500305	10	50	
330000	5	29		3100006	8	1		3500402	12	10	
330006	6	18		3100006	13	4		3500403	5	11	
330006	11	31		3100008	21	9		3500432	2	25	
330013	5	32		3100016	2	24		3500505	19	5	
				3100036	21	17					
340000	1	14		3100061	12	3		3501270	14	13	
340003	10	52		3100122	6	7		3501272	14	28	
340022	2	57		3100123	12	34		3501275	14	32	
340051	2	11		3100127	5	12		3501276	14	27	
340053	10	27		3100129	5	6		3501281	13	18	
				3100129	6	2		3501282	14	24	
350009	3	25		3100192	13	24		3501283	14	17	
350013	19	25		3100205	2	8		3501284	14	19	
				3100283	5	10		3501295	14	33-2	
390188	1	5		3100329	12	5					
				3100330	12	35		4109403	1	15	
910000	20	10		3100345	12	4					
910001	20	7		3100370	12	16		4200008	2	37	
910003	20	14		3100383	3	22		4200013	1	1	
				3100384	3	23		4200014	1	2	
911001	20	6		3100386	3	24		4200015	2	43	
911002	20	5		3100387	3	37		4200016	2	34	
911006	20	9		3100533	10	40		4200017	2	30	
911060	20	19		3100600	13	28		4200018	2	26	
				3100601	13	27		4200019	1	11	
930052	20	12		3100602	13	23		4200020	2	13	
930053	20	13		3100603	13	26		4200021	2	1	
930055	20	27		3100605	13	12		4200022	2	32	
				3100607	13	5		4200023	3	30	
1090238	19	11		3100609	15	25		4200024	3	19	
1090239	19	10		3100612	14	3		4200025	8	10	
				3100613	14	5		4200026	2	7	
1091162	19	3		3100614	15	19					

# INDEX

Parts No.	Page No.	Ref. No.	Weight (g)	Parts No.	Page No.	Ref. No.	Weight (g)	Parts No.	Page No.	Ref. No.	Weight (g)
4200027	2	5		4200099	5	26		4200168	6	28	
4200028	2	10		4200100	4	3		4200169	6	25	
4200029	6	4		4200101	10	4		4200170	6	36	
4200030	1	12		4200102	10	14		4200171	6	35	
4200031	2	44		4200103	10	8		4200172	6	34	
4200033	3	28		4200104	10	3		4200173	6	33	
4200034	1	18		4200108	5	9		4200174	6	31	
4200035	3	3		4200109	6	6		4200175	6	27	
4200036	3	5		4200110	7	5		4200176	2	46	
4200037	2	60		4200111	7	7		4200177	2	48	
4200038	2	56		4200112	7	15		4200178	11	10	
4200039	2	51		4200113	7	10		4200179	4	10	
4200040	2	52		4200114	7	1		4200180	4	11	
4200041	2	22		4200115	7	8		4200182	11	14	
4200042	2	23		4200116	7	6		4200184	6	26	
4200043	3	1		4200117	7	13		4200185	6	37	
4200044	2	15		4200118	7	4		4200186	11	11	
4200045	2	18		4200119	7	20		4200187	11	17	
4200046	2	21		4200120	7	18		4200188	11	1	
4200047	3	26		4200121	8	16		4200199	12	13	
4200048	9	18		4200122	6	10		4200200	9	37	
4200049	1	7		4200123	6	11		4200203	12	27	
4200050	1	6		4200124	6	14		4200204	12	22	
4200051	2	50		4200125	6	16		4200206	12	15	
4200052	10	39		4200126	6	9		4200208	12	19	
4200055	5	3		4200127	4	21		4200210	12	32	
4200056	18	1		4200128	4	20		4200211	12	8	
4200057	18	2		4200129	4	14		4200212	12	33	
4200058	22	13		4200130	8	7		4200213	5	8	
4200060	6	17		4200131	8	13		4200214	6	5	
4200062	4	12		4200132	8	9		4200220	21	1	
4200063	4	13		4200133	8	6		4200300	3	32	
4200064	6	19		4200134	8	12		4200301	3	33	
4200065	5	1		4200135	8	17		4200302	22	11	
4200066	6	40		4200136	4	8		4200303	22	1	
4200067	5	20		4200137	4	17		4200304	22	4	
4200070	5	14		4200138	4	18		4200306	22	9	
4200071	5	15		4200139	4	16		4200307	22	6	
4200072	9	14		4200140	4	15		4200308	13	13	
4200073	9	15		4200141	2	16		4200309	14	26	
4200076	9	16		4200142	6	41		4200311	14	1	
4200078	9	24		4200150	6	38		4200312	15	7	
4200080	9	2		4200151	11	33		4200313	16	13	
4200081	9	39		4200152	6	39		4200314	14	29	
4200082	9	1		4200153	11	30		4200315	16	5	
4200083	9	25		4200154	11	25		4200317	16	1	
4200084	4	5		4200155	8	3		4200318	15	33	
4200085	9	27		4200155	11	29		4200319	14	22	
4200086	9	35		4200156	11	21		4200320	14	35	
4200087	9	31		4200157	11	22		4200321	16	11	
4200088	9	32		4200158	11	19		4200322	16	10	
4200089	9	11		4200159	11	34		4200323	16	3	
4200090	9	12		4200160	11	12		4200324	13	6	
4200091	9	10		4200161	11	15		4200325	16	16	
4200092	9	8		4200162	4	9		4200326	14	33 - 1	
4200094	9	7		4200163	4	7		4200327	16	14	
4200095	9	30		4200164	4	6		4200328	15	20	
4200096	9	5		4200165	11	5		4200329	13	1	
4200097	4	23		4200166	11	3		4200330	14	37	
4200098	5	31		4200167	6	32					

# INDEX

Parts No.	Page No.	Ref. No.	Weight (g)	Parts No.	Page No.	Ref. No.	Weight (g)	Parts No.	Page No.	Ref. No.	Weight (g)
4200331	13	33		4209003	17	3					
4200332	16	8		4209004	17	25					
				4209100	9	19					
4201000	19	2		4209101	18	13					
4201002	19	1		4209103	17	1					
4201010	23	1-2		4209104	17	23					
4201011	23	6-2		4209200	11	40					
4201014	23	2		4209200	18	17					
4201015	23	4		4209201	7	29					
4201017	23	1-3		4209201	18	20					
4201018	23	6-3		4209301	8	18					
4201019	23	1-1		4209305	18	25					
4201020	23	6-1		4209309	17	5					
				4209311	17	27					
4207000	10	18		4209315	7	25					
4207000	17	11		4209316	18	24					
4207000	18	31		4209318	17	4					
4207001	10	24		4209319	17	26					
4207001	17	16		4209325	7	27					
4207001	18	36		4209325	18	22					
4207002	10	16		4209326	7	33					
4207002	17	9		4209326	18	19					
4207002	18	29									
4207003	10	28		6920660	20	28					
4207004	10	29									
4207005	10	23		9620631	20	2					
4207006	10	30		9620665	20	22					
4207007	10	15		9620668	20	29					
4207008	10	21		9620670	20	3					
4207008	17	13		9620673	20	8					
4207008	18	33		9620675	20	11					
4207010	10	31		9620678	20	23					
4207010	17	7		9620679	20	24					
4207010	18	27		9620680	20	25					
4207011	10	25		9620681	20	26					
4207011	17	17		9620688	20	18					
4207011	18	37		9620689	20	4					
4207015	18	40		9620690	20	21					
4207016	18	42		9620691	20	20					
4207017	18	35		9620694	20	1-1					
4207018	18	41		9620699	20	1-2					
4207019	18	26		9620700	20	17					
4207020	17	20		9620702	20	15					
4207021	17	22		9620703	20	16					
4207022	17	15									
4207023	17	21									
4207024	17	6									
4207025	17	30									
4207026	17	32									
4207027	17	29									
4207028	17	31									
4207029	17	28									
4208000	9	22									
4208001	18	15									
4208003	17	2									
4208004	17	24									
4209000	11	38									
4209001	18	16									



***Yamato***

ヤマトミシン製造株式会社

***YAMATO SEWING MACHINE MFG. CO., LTD.***

4-4-12, NISHITENMA, KITA-KU, OSAKA, JAPAN  
TEL : 81-6-6364-1321 FAX : 81-6-6364-1307  
〒530-0047 大阪市北区西天満4丁目4番12号  
TEL(06)6364-1321(代) FAX(06)6365-5176